

- 
- A close-up photograph of a Bioflex PTFE hose. The hose features a braided stainless steel reinforcement layer over a smooth PTFE inner lining. It is connected to a white plastic fitting. The background is a soft, out-of-focus green and blue gradient.
- C H E M I C A L R E S I S T A N T
 - S E L F - C L E A N I N G
 - F L E X I B L E
 - H Y G I E N I C

Bioflex

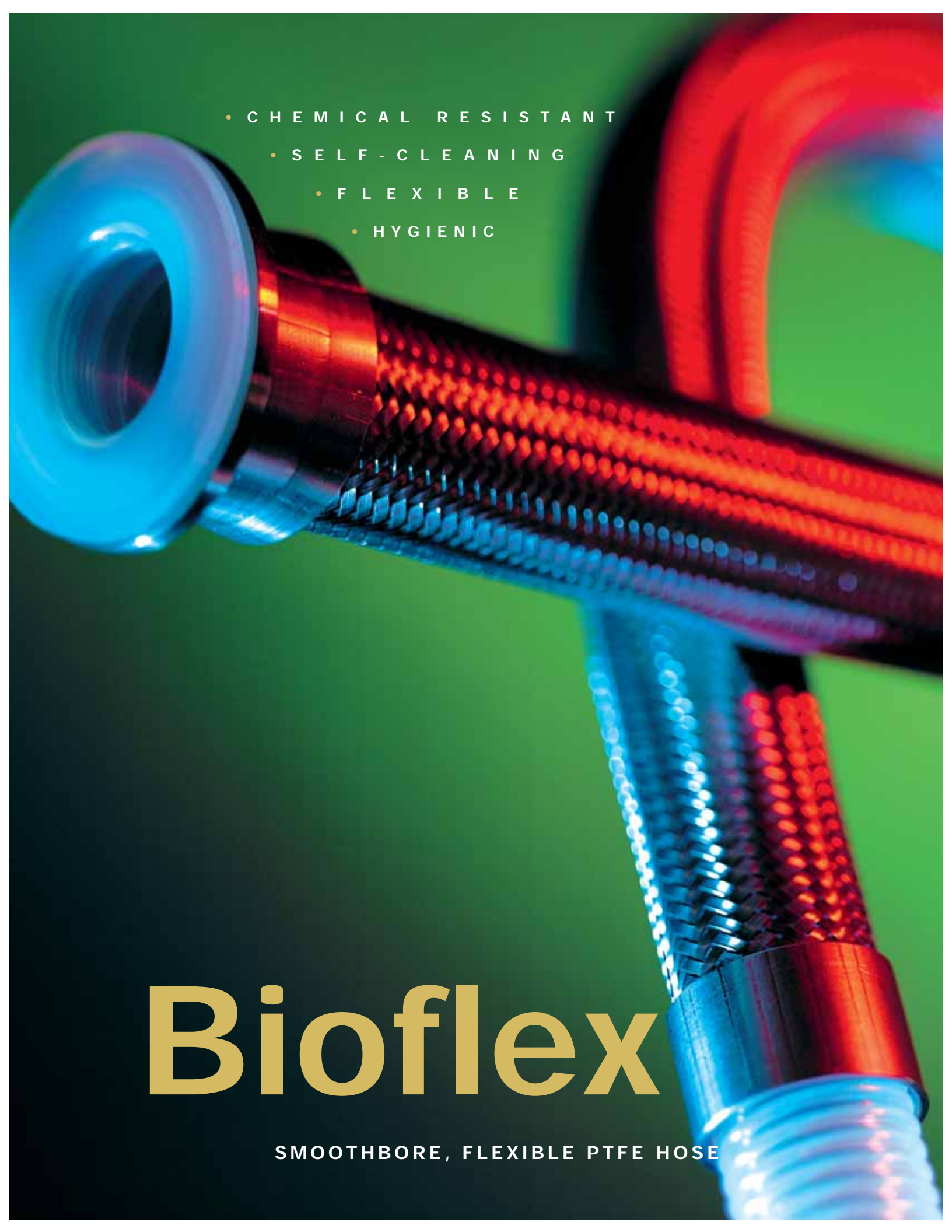

SMOOTHBORE, FLEXIBLE PTFE HOSE

Contents

Front Cover	Page 1
Contents	Page 2
PTFE - The Optimum Choice For Hose Linings	Page 3
Aflex Hose and Bioflex	Page 4
Bioflex Hose Design and Comparative Properties	Page 5
Bioflex Hose - Special Test Programs	Pages 6 & 7
Bioflex Temperatures, Pressures & Flow Rates	Page 8
Bioflex Sizes, Grades, Bend Radius and Dimensions	Page 9
Bioflex Sizes, Grades, Pressure Ratings and Weights	Page 10
Bioflex Special Usage Conditions	Page 11
Quality Assurance Certification & Approvals and Hose Testing	Page 12
How to Order Bioflex	Page 13
Bioflex Part Number System	Page 14
<u>HOSE</u>	
Bioflex Hose Liners	Page 15
Bioflex Hose Braids	Page 16
Bioflex Rubber Covers	Page 17
Bioflex External Protection Systems	Page 18
<u>FLANGE FITTINGS</u>	
Flange Fittings, Non-Lined	Page 19
Flange Fittings, PTFE Lined	Page 20
<u>CAM AND GROOVE FITTINGS (CAMLOCKS)</u>	
Female Cam & Groove Fittings, PTFE Lined and Not Lined	Page 21
Male Cam & Groove Fittings, PTFE Lined and Not Lined and Cam Male-to-Flange Adaptors, PTFE Lined	Page 22
<u>SANITARY (TRICLOVER) FITTINGS</u>	
Mini Sanitary & Sanitary Triclover Fittings, PTFE Lined	Page 23
Sanitary Triclover Fittings, PTFE Lined and "Beaded"	Page 24
Mini Sanitary & Sanitary Triclover Fittings, Not Lined	Page 25
90° Elbow Sanitary Triclover Fittings, Not Lined	Page 26
<u>HYGIENIC FITTINGS (EUROPEAN)</u>	
DIN 11851 Male & Female Fittings, PTFE Lined	Page 27
SMS and RJT Female Fittings, PTFE Lined	Page 28
<u>BSP, NPT & JIC THREADED FITTINGS (Not Lined)</u>	
NPT & BSPT Fixed Male and NPT Fixed Female Fittings	Page 29
BSP 60° Cone Seat Female Fittings and Lug-Type Female Fittings	Page 30
37° JIC Female Fittings & Adaptors	Page 31
<u>PTFE Dip Pipes</u>	
PTFE Dip Pipes, Straight or 90° Elbow	Page 32
<u>90° ELBOW FITTINGS</u>	
90° Elbow Fittings, PTFE Lined and Non-Lined	Page 33
<u>HEAT JACKETED HOSE ASSEMBLIES</u>	
Steam Heated Hose Assemblies (CH Grade)	Page 34
Electrically Trace Heated Hose Assemblies (ETH Grade)	Page 35
<u>BIOFLEX STANDARD AND PURETAG LABELLING & COLOUR CODING</u>	
Page 36	
<u>CORRECT HOSE CONFIGURATION & LENGTH CALCULATIONS</u>	
- for Bend Radius	Page 37
- for Abrasion & Torque	Page 38
- for Length Calculation	Page 39
<u>CONDITIONS OF SALE</u>	
Page 40	

PTFE - The Optimum Choice For Hose Linings

Section from a PTFE Molecule,
16 Angstrom Units long.

 = Fluorine Atom
 = Carbon Atom

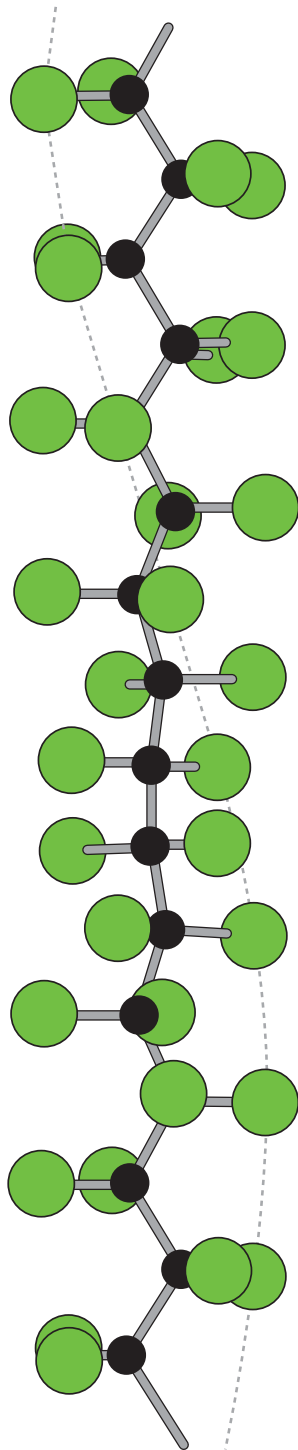

PTFE, or Polytetrafluoroethylene, comprises long-chain molecules of carbon atoms, each linked to two fluorine atoms.

The fluorine atoms provide a helical spiral which surrounds the carbon chain and protects it.

It is this structure which creates the unique properties for which PTFE is well-known.

Excellent Chemical Resistance

PTFE is renowned as the most chemically resistant material known. Only a very few, very unusual substances and conditions can affect it, like Fluorine gas at high temperature and pressure and liquid, boiling sodium metal.

PTFE lined hoses can therefore be used for a wider variety of chemicals than any other hose type, making it the ideal choice for very corrosive chemical applications and multi-product applications.

Non-Stick Surface

The use of PTFE as a surface for cookware products has demonstrated to the world how easily cleanable PTFE surfaces are.

This means that PTFE lined hoses can be purged 100% clean more quickly, easily and reliably than any other type of hose.

Excellent Temperature Range

The cookware application also demonstrates another of PTFE's many attributes - temperature resistance. PTFE itself can be used as a hose liner at temperatures from -150°C up to $+260^{\circ}\text{C}$, dependent upon the hose design and the application conditions.

This is the widest temperature range of any rubber or plastic hose lining material.

Very High Electrical Resistance

Most aerospace electrical wiring has a PTFE cover, due to the excellent electrical resistance of PTFE. This property is, however, a disadvantage in some hose applications where there is a risk of developing an electrostatic charge inside the hose bore. Aflex Hose have developed a non-contaminant, FDA and USP Class VI compliant solution to this problem.

Hose Design

The only issue with PTFE as a hose lining material is the best way it can be integrated in to the hose design. This is where Aflex Hose have a proven record of success over the last 30 years.

Aflex Hose and BIOFLEX[®]

The World's Leading Manufacturer of PTFE Flexible Hose



Aflex Hose, founded in 1973, pioneered the concept of PTFE lined flexible hose for the transfer of process fluids more than 30 years ago.

Corroflon convoluted PTFE hose and other types of PTFE hose, manufactured and supplied by Aflex, are used by major Chemical, Pharmaceutical and Food companies worldwide.

Over the years, hundreds of thousands of custom-built hoses have been designed and built to cope with the most difficult of operating conditions, and Aflex have continuously developed and expanded their product range having pioneered and introduced Antistatic hose, Polypropylene Braided hose and many other innovations in response to customer demands.

In 2001, Aflex fulfilled the most stringent demand yet.

Customers, worldwide, had always asked for the ultimate PTFE lined flexible hose... one product which incorporates the advantages of both convoluted and smoothbore designs. A product which is sufficiently flexible, like convoluted, yet which retains the advantages offered by smoothbore, like fast flow rate and cleanability.

After years of painstaking research and development, Aflex launched such a hose ... **Bioflex**.

Bioflex is a smooth bore, highly flexible, PTFE lined hose. Its design overcomes the disadvantages of conventional smooth bore and convoluted PTFE flexible hose designs, dramatically improving on many of their individual technical performance parameters.

The key feature of Bioflex PTFE hose is the PTFE liner design, which comprises integral rib sections which support the tube against kinking, vacuum and pressure, and highly compressed web sections which give a smoothbore inner surface and excellent flexibility.

Another feature is the integral PTFE lined and flared end fitting design (see next page) which is available for all the standard end fittings on Bioflex Hose Assemblies.

This provides clean, full-bore flow through the end fitting without any entrapment points - unlike conventional fittings, which introduce a bore restriction, also a crevice at the end of the fitting tail.

This PTFE lining also protects the end fitting from any corrosive media passing through the hose bore.

Today, Bioflex has become the established standard in process fluids applications all over the world, and continues to be introduced into new applications every day.

Conventional Convoluted PTFE Liner

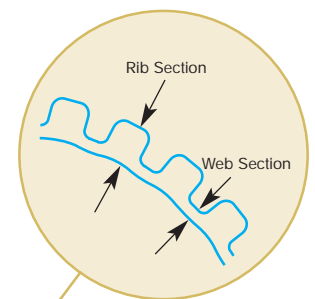
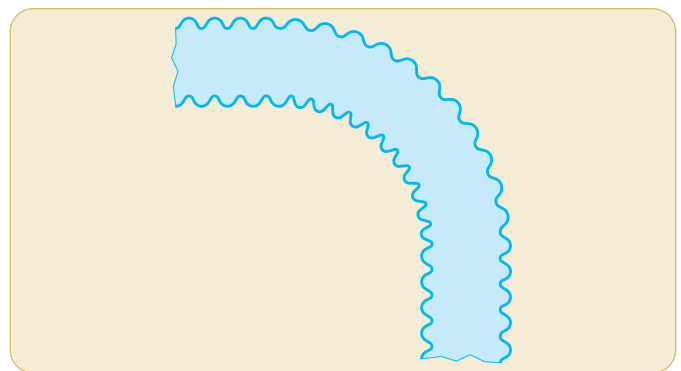

Bioflex PTFE Liner

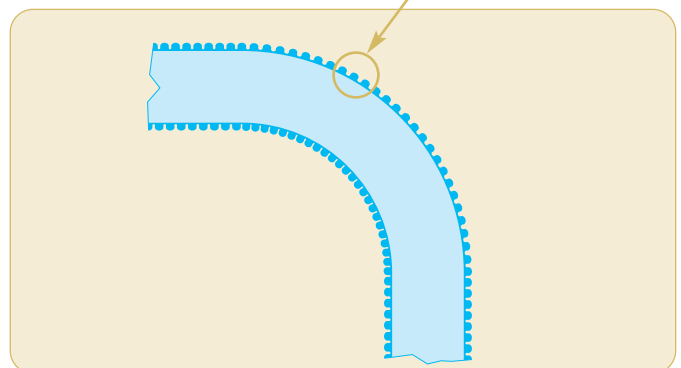

[®] **Bioflex is a Patent Protected Product**

Bioflex Hose-Design and Comparative Properties

Bioflex Hose Design Options

Bioflex Hose Grades are made up by combining the Design Options, which are designated by 2 or 3 letters as shown below, and fully described on the indicated pages.

For example, "Bioflex AS, PB, SG" defines a hose with an Antistatic PTFE liner (AS) and a Polypropylene braid (PB) and an outer "Safeguard" (SG) spiral HDPE protection sleeve.

PTFE Liner Tube Options - GP or AS - Page 15

Braid Options - TO, SS, HB, PB, KYB - Page 16

External Rubber Cover Options - RC, SI, FP and RC-300 - Page 17

External Protection Options - KR, SR, SG and PC - Page 18

BIOFLEX GP, SS WITH A PTFE LINED FLANGE FITTING

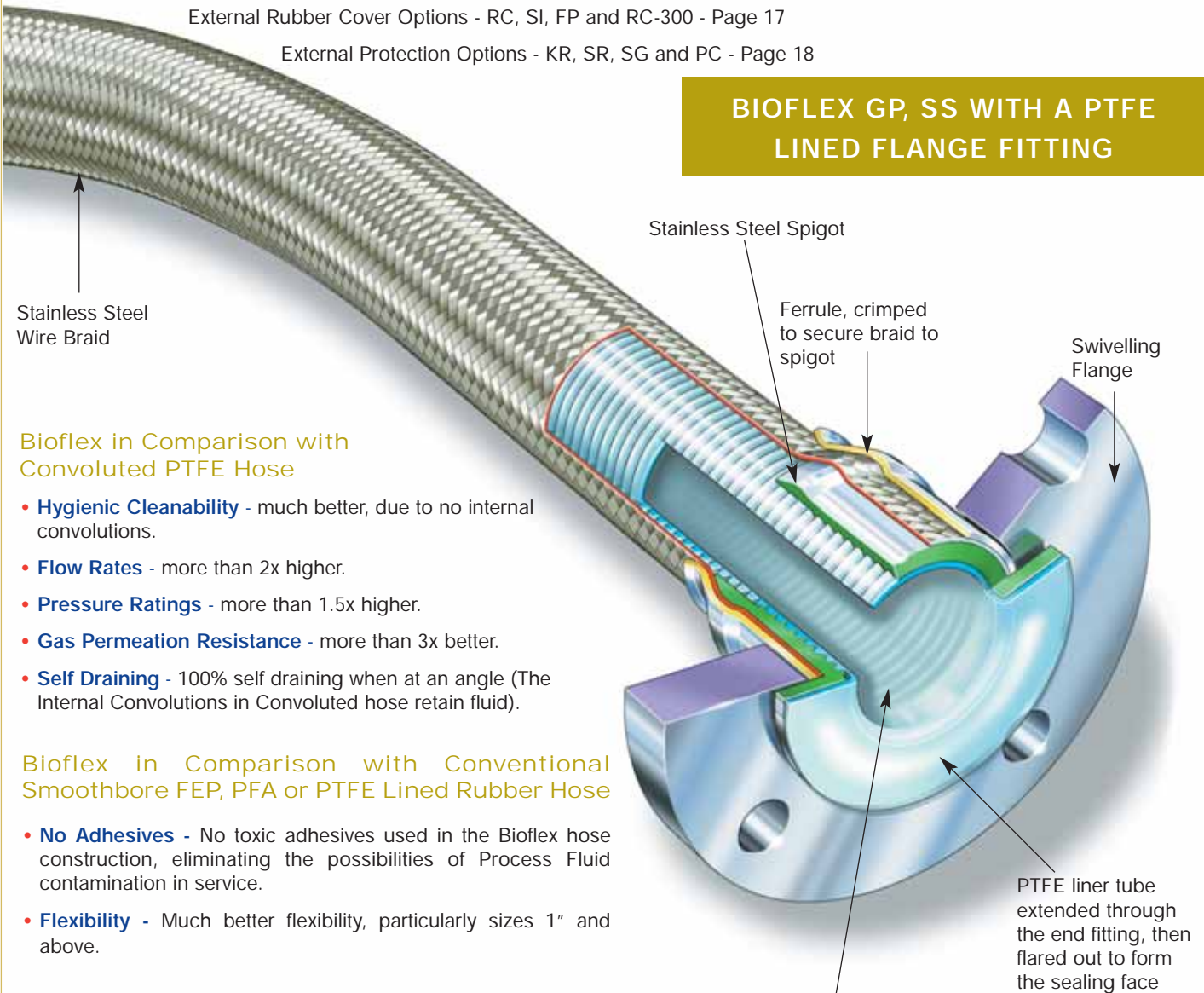

Bioflex in Comparison with Convoluted PTFE Hose

- **Hygienic Cleanability** - much better, due to no internal convolutions.
- **Flow Rates** - more than 2x higher.
- **Pressure Ratings** - more than 1.5x higher.
- **Gas Permeation Resistance** - more than 3x better.
- **Self Draining** - 100% self draining when at an angle (The Internal Convolutions in Convoluted hose retain fluid).

Bioflex in Comparison with Conventional Smoothbore FEP, PFA or PTFE Lined Rubber Hose

- **No Adhesives** - No toxic adhesives used in the Bioflex hose construction, eliminating the possibilities of Process Fluid contamination in service.
- **Flexibility** - Much better flexibility, particularly sizes 1" and above.

Bioflex in Comparison with Silicone Rubber Hose

- **Hygienic Cleanability** - much better, due to the non-stick PTFE Liner.
- **Chemical Resistance** - considerably improved, particularly to strong oxidising acids and bases.
- **Temperature & Pressure Ratings** - much higher temperature and pressure capability.
- **Steam Resistance** - permanently resistant to steam sterilising (unlike silicone hose, which has a limited life).

Bioflex PTFE liner tube:

- externally convoluted
- smooth bore, with slight ripples
- internal surface finish is 'mirror smooth', generated by hot polishing during manufacture

Bioflex Hose - Special Test Programs (1)

Bioflex has been designed to fulfil the most demanding of customer expectations and, as such, has been subjected to a highly complex and rigorous Proof Testing Programme in comparison with competitive hose products.

Test No. 1. The 'Rolling U' Test.

Bioflex samples were run side by side with competitors' products, including smoothbore FEP, PTFE or PFA lined Rubber hose products, and also smooth flex products, on a 'Rolling U' test rig.

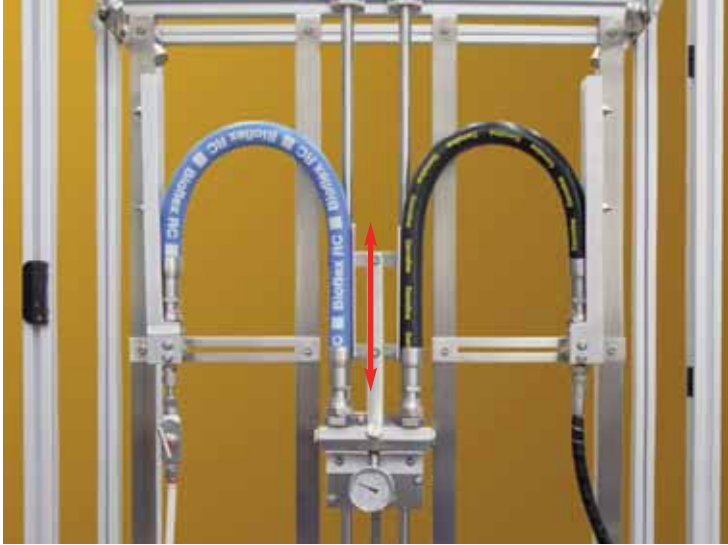

The 1" bore samples were "Rolled" at the minimum bend radius and at the maximum working pressure quoted for the competitor's product.

Results were as follows:

- Rubber Covered Bioflex Hose - 1,500,000 cycles, no failure.
- No leakage occurred, so test discontinued. No signs of damage, or wear.
- Competitor's smoothbore FEP lined Rubber Covered Hose - 9,149 cycles to failure.
- Hose leakage caused by severe failure of the hose liner, breakage of the helix wire and damaged rubber and braid.
- Competitor's convoluted smooth flex type hose, SS Braid - 7,151 cycles to failure.
- Hose leakage caused by very severe failure of the hose liner and braid components.

These remarkable results confirm the claims made by Aflex, that Bioflex is the best designed, toughest and most reliable PTFE lined hose product available today.

Bioflex Hose - Special Test Programs (2)

Test No. 2. The Permeability Test.

Fixed lengths of Bioflex were pressurised to 30 Bar with Helium Gas, and compared with samples of standard convoluted PTFE hose.

Results

Bioflex has more than 2.5 x the permeation resistance of standard convoluted hose. Under identical conditions, the permeation levels were:

1" Bioflex = 138 millilitres of helium per metre per hour

1" Convoluted = 371 millilitres of helium per metre per hour

The permeability, or diffusion of gases and some fluids through PTFE is a problem in certain, very specific applications. Bioflex hose offers significant advantages in such applications.

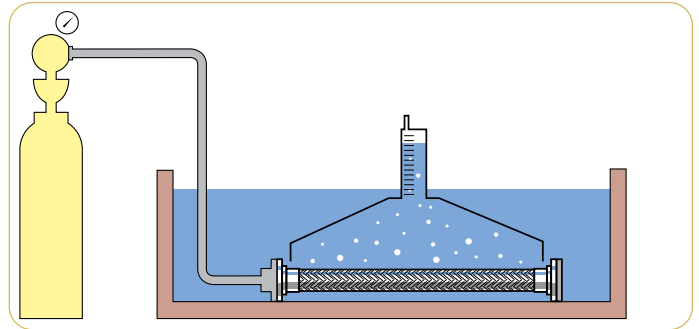

Test No. 3. The Flow Rate Test.

The test apparatus illustrated opposite was used to measure the flow rate of Bioflex, both in a straight configuration and coiled to its Minimum Bend Radius. The test medium was water.

Results

Comparisons were made with samples of standard convoluted hose with the same diameter on the inside of the convolutions as the Bioflex inside diameter. These show that Bioflex is capable of delivering 2 - 3 times the flow rate of convoluted hose, in both the hose configurations.

Additional tests have shown that the flow rate through a Bioflex hose is actually greater than that of a convoluted hose which is one size larger. For example, 1½" Bioflex has a higher flow rate than 2" convoluted hose. It is therefore possible to use a smaller Bioflex hose, fitted with full size end fittings, to replace a convoluted hose more effectively, and more economically!

This remarkable improvement is due to the fact that the turbulent flow created by the convolutions in the standard product is virtually eliminated by the much smoother bore of Bioflex.

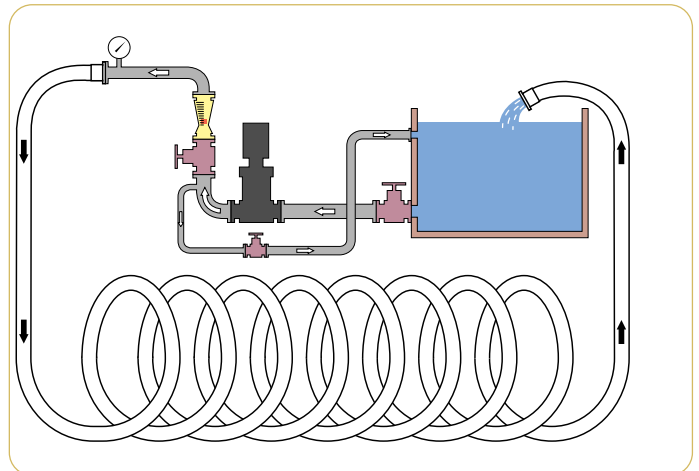

Bioflex Specifications.

Temperatures, Pressures & Flow Rates

Temperature vs Pressure

Due to its extremely strong construction, Bioflex has outstanding resistance to temperature and pressure, much higher than that of conventional convoluted PTFE lined hose.

Maximum Working Pressure (MWP) Variation with Temperature:

Hose with SS Braid as per Graph.

Hose with PB Braid, pressure as listed (Page 10) from -22°F through +176°F and 50% less from 176°F through 212°F.

Hose with RC, FP and SI grades as per Graph, BUT only within the temperature range for the particular grade of rubber cover, as given below.

Operating Temperature Limits (Internal Fluid Only):

SS	-94°F through +500°F
PB	-22°F through +212°F
SS,RC & SS, FP	-40°F through +284°F
SS, SI	-40°F through +392°F
KYB	-40°F through +248°F

(Subtract 36°F from the above maximum temperature limits if the temperature is external to the hose).

Flow Rates

In practice, flow rates will vary with hose flexing, fluid viscosity, end fitting design and other parameters, but Bioflex hose flow rates are always around 2 times better than convoluted PTFE hose, when comparing hose assemblies with PTFE lined (non bore-restricted) end fittings.

Bioflex Hose - Flow Rate Calculation

If it is required to determine the flow rate of a particular hose assembly, or if it is required to determine the pressure required to generate a certain flow rate, then this can sometimes be approximately calculated by the Bioflex supplier.

It should be noted that calculations can only be made for fluids with a viscosity equal to water, and for hose assemblies with PTFE lined end fittings (no bore restrictions at the ends of the hose).

The following information should be given to the supplier:

To calculate the Flow Rate in gallons per hour:

- Pressure in psi at the Entry into the Hose Assembly
 - Pressure in psi at the Exit from the Hose Assembly
 - The hose configuration (roughly straight, or 33% Bends, or 66% Bends, or 100% tightly coiled)
- > (Subtracted to calculate Pressure Drop over the Hose Length)

OR To Calculate the Pressure Drop in psi over the length of the Hose Assembly:

- Required Flow Rate in gallons per hour
- The hose configuration (roughly straight, or 33% Bends, or 66% Bends, or 100% tightly coiled)

Non-Whistling

The 'whistling' noise created by turbulent flow when steam or other gasses are passed through a convoluted hose is completely eliminated when using Bioflex.

Temperature & Pressure Resistance Graph for Bioflex GP, SS and AS, SS

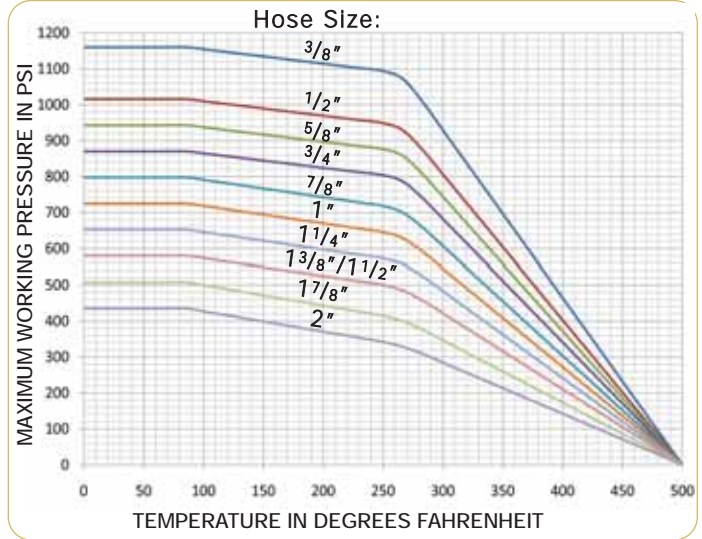

Temperature vs Vacuum

All sizes of Bioflex GP,SS and AS,SS are usable at full vacuum up to 266°F. Above this, the vacuum resistance should be reduced 1% for every 1.8 degrees above 266°F.

Rubber covered grades the same, BUT ONLY within the temperature limits for the type of rubber.

All sizes of Bioflex TO, GP and AS, TO are fully vacuum resistant up to 212°F.

Bioflex Sizes, Grades, Bend Radius and Dimensions

Nominal Hose Bore Size		Actual Bore Size		Bioflex Grade (Braid & Cover)	O/D of Tube, Braid or Rubber		Minimum Bend Radius		*Maximum Continuous Hose Length	
in	mm	in	mm		in	mm	in	mm	Ft	Mtrs
3/8	10	3/8	9.5	TO	0.47	12.0	1 3/8	35	60	18
				SS	0.50	12.8	3/4	19	60	18
				RC	0.68	17.4	3/4	19	60	18
1/2	15	1/2	12.7	TO	0.60	15.5	2 3/8	60	60	18
				SS	0.65	16.6	1 1/2	38	60	18
				PB	0.77	19.5	1 1/2	38	60	18
				RC/FP	0.83	21.0	1 1/2	35	60	18
				SI	0.83	21.0	1 1/2	35	60	18
				KYB	0.69	17.5	1 1/2	35	60	18
5/8	16	5/8	16.0	TO	0.76	19.4	2 1/2	64	60	18
				SS	0.81	20.6	1 3/4	45	60	18
				PB	0.92	23.3	1 3/4	45	60	18
				RC/FP	0.98	25.0	1 3/4	45	60	18
				SI	0.98	25.0	1 3/4	45	60	18
				KYB	0.85	21.5	2 1/2	64	60	18
3/4	20	3/4	19.0	TO	0.91	23.2	3	75	60	18
				SS	0.96	24.5	2	50	60	18
				PB	1.10	27.9	2	50	60	18
				RC/FP	1.20	30.4	2	50	60	18
				SI	1.20	30.4	2	50	60	18
				KYB	1.62	26.0	3	75	60	18
7/8	22	7/8	22	TO	1.06	27.0	3 1/2	90	60	18
				SS	1.11	28.2	2 3/8	60	60	18
				PB	1.26	32.0	2 3/8	60	60	18
				RC/FP	1.31	33.2	2 3/8	60	60	18
				SI	1.31	33.2	2 3/8	60	60	18
				KYB	1.17	29.7	3 1/2	90	60	18
1	25	1	25.4	TO	1.22	31.0	4 3/4	110	60	18
				SS	1.27	32.3	2 3/4	70	60	18
				PB	1.48	37.7	2 3/4	70	60	18
				RC/FP	1.47	37.7	2 3/4	70	60	18
				SI	1.47	37.7	2 3/4	70	60	18
				KYB	1.31	33.4	4 3/4	110	60	18
1 1/4	32	1 1/4	32	TO	1.47	37.3	5 1/2	140	60	18
				SS	1.56	39.5	4	100	60	18
				PB	1.74	44.3	4	100	60	18
				RC/FP	1.75	44.3	4	100	60	18
				SI	1.75	44.5	4	100	60	18
				KYB	1.56	39.7	5 1/2	140	60	18
1 3/8	35	1 3/8	34.9	TO	1.62	41.2	6 1/2	160	60	18
				SS	1.70	43.1	4 3/4	120	60	18
				PB	1.88	47.8	4 3/4	120	60	18
				RC/FP	1.90	48.1	4 3/4	120	60	18
				SI	1.90	48.1	4 3/4	120	60	18
				KYB	1.69	42.9	6 1/4	160	60	18
1 1/2	40	1 1/2	38	TO	1.77	45.0	7	180	56	17
				SS	1.85	47.0	5 1/2	140	56	17
				PB	2.00	50.8	5 1/2	140	56	17
				RC/FP	2.05	52.0	5 1/2	140	56	17
				SI	2.05	52.0	5 1/2	140	56	17
				KYB	1.88	47.7	7	180	56	17
1 7/8	48	1 7/8	47.6	TO	2.17	55.2	11	280	43	13
				SS	2.25	57.1	7 1/2	190	43	13
				PB	2.44	62.0	7 1/2	190	43	13
				RC/FP	2.45	62.1	7 1/2	190	36	11
				SI	2.45	62.1	7 1/2	190	36	11
				KYB	2.25	57.3	11	280	43	13
2	50	2	50.8	TO	2.33	59.1	12	300	33	10
				SS	2.40	61.0	8	200	33	10
				PB	2.60	66.0	8	200	33	10
				RC/FP	2.60	66.0	8	200	26	8
				SI	2.60	66.0	8	200	26	8
				KYB	2.43	61.7	12	300	33	10

*Maximum Continuous Lengths - for sizes from 3/8", 10mm up to 1", 25mm lengths of up to 36 mtrs, 120 ft, can be supplied to special order.

Bioflex Sizes, Grades, Pressures & Weights

Nominal Hose Bore Size		Actual Bore Size		Bioflex Grade (Braid & Cover)	Maximum Working Pressure of Hose*		Burst Pressure		Weight per Unit Length	
in	mm	in	mm		Bar (N/m ²)	psi	Bar (N/m ²)	psi	Kg/Mtr	lb/ft
3/8	10	3/8	9.5	TO	5	72	20	290	.06	.04
				SS	80	1160	500	7200	.14	.09
				RC	80	1160	500	7200	.22	.15
1/2	15	1/2	12.7	TO	5	72	20	290	.15	.10
				SS	70	1015	400	5800	.29	.19
				PB	35	500	140	2000	.22	.15
				RC/FP	70	1015	400	5800	.39	.26
				SI	70	1015	400	5800	.39	.26
				KYB	10	145	40	580	.19	.13
5/8	16	5/8	16.0	TO	5	72	20	290	.17	.11
				SS	65	940	380	5500	.35	.23
				PB	33	480	130	1900	.25	.17
				RC/FP	65	940	380	5500	.47	.31
				SI	65	940	380	5500	.47	.31
				KYB	10	145	40	580	.20	.13
3/4	20	3/4	19.0	TO	5	72	20	290	.20	.13
				SS	60	870	300	4350	.40	.27
				PB	30	440	120	1750	.28	.19
				RC/FP	60	870	300	4350	.55	.37
				SI	60	870	300	4350	.55	.37
				KYB	10	145	40	580	.24	.16
7/8	22	7/8	22	TO	4	60	16	230	.28	.19
				SS	55	800	220	3200	.52	.35
				PB	27.5	400	110	1600	.38	.25
				RC/FP	55	800	220	3200	.74	.50
				SI	55	800	220	3200	.74	.50
				KYB	10	145	40	580	.33	.22
1	25	1	25.4	TO	4	60	16	230	.36	.24
				SS	50	720	200	2900	.63	.42
				PB	25	360	100	1450	.47	.31
				RC/FP	50	720	200	2900	.92	.62
				SI	50	720	200	2900	.92	.62
				KYB	10	145	30	430	.41	.27
1 1/4	32	1 1/4	32	TO	3	43	12	175	.45	.30
				SS	45	650	180	2600	.85	.57
				PB	23	330	90	1300	.72	.48
				RC/FP	45	650	180	2600	1.15	.77
				SI	45	650	180	2600	1.15	.77
				KYB	6	87	24	350	.53	.35
1 3/8	35	1 3/8	34.9	TO	2	29	8	115	.54	.36
				SS	40	580	160	2320	1.00	.67
				PB	20	290	80	1160	.86	.58
				RC/FP	40	580	160	2320	1.38	.92
				SI	40	580	160	2320	1.38	.92
				KYB	6	87	20	290	.68	.45
1 1/2	40	1 1/2	38	TO	2	29	8	115	.66	.44
				SS	40	580	160	2320	1.10	.74
				PB	20	290	80	1160	.90	.60
				RC/FP	40	580	160	2320	1.55	1.04
				SI	40	580	160	2320	1.55	1.04
				KYB	6	87	20	290	.78	.52
1 7/8	48	1 7/8	47.6	TO	2	29	8	115	.82	.55
				SS	35	500	140	2000	1.38	.92
				PB	18	250	72	1040	1.12	.75
				RC/FP	35	500	140	2000	1.94	1.30
				SI	35	500	140	2000	1.94	1.30
				KYB	6	87	16	230	.97	.65
2	50	2	50.8	TO	2	29	8	115	1.25	.84
				SS	30	430	120	1750	1.90	1.27
				PB	15	215	60	870	1.60	1.07
				RC/FP	30	430	120	1750	2.56	1.71
				SI	30	430	120	1750	2.56	1.71
				KYB	6	87	12	175	1.42	.95

*MWP: the Maximum Working Pressure of a hose assembly is limited to the lowest of the MWP's of either of the two end fittings, as given for each end fitting design on pages 19-33, or of the hose itself as listed above. MWP of the hose reduces with Temperature as given on page 8

Bioflex Hose: Special Usage Conditions

Cleaning & Sterilising Systems - CIP, SIP and Autoclave

CIP & SIP – PTFE liner tubes are chemically resistant to all CIP, SIP and Autoclave conditions. The primary consideration is whether the cleaning and purging cycle is likely to develop an electrostatic charge on the internal surface of the liner, in which case AS (Anti-Static) grade hose is required.

AS grade hose and Electrostatic charge generating systems are fully described in the hose liner section.

CIP systems using high electrical resistivity solvents like Toluene will require AS grade hose.

Another electrostatic generation problem arises when wet steam is used, or when the cleaning fluids or WFI are purged out of the line using nitrogen, compressed air or another gas, because droplets of liquid or water in the gas then generate a multi-phase condition until they are cleared out, which will generate a static charge, and so will require AS grade hose.

In static generating applications where AS grade hose is not acceptable due to the black PTFE liner, alternative solutions are available – please consult Aflex Hose for advice.

Autoclave – Autoclave sterilisation does not normally involve any high flow rates through the hose bore, so static generation is not a problem. Aflex hose grades GP and AS, with SS or HB braids are fully resistant to all autoclave conditions throughout the service life of the hose.

The rubber covered grades EPDM, (RC) and Silicone Rubber (RC, SI) are able to withstand at least 100 x 30 minute autoclave cycles at relatively high autoclave temperatures (upto 135°C, 275°F). Consult Aflex Hose for more specific information.

PTFE Hose-Use with Alkali Metals, Halogens and Halogen containing Chemicals

PTFE hose liners react chemically with Fluorine, Chlorine Trifluoride and molten Alkali Metals.

When PTFE lined hose is used to carry Chlorine or Bromine, either as gasses or fluids, they will diffuse into and through the PTFE liner wall thickness. Trace quantities will then combine with atmospheric moisture to corrode any braid/rubber outer coverings.

Heavily halogenated chemicals, like Hydrogen Fluoride, Hydrogen Chloride, Phosgene (Carbonyl Chloride) Carbon Tetrachloride and other organic chemicals with a high halogen content can also be absorbed and transmitted through the PTFE liner tube.

Other “Penetrating” Fluids and Gases

Sulphur Trioxide, Methyl Methacrylate and Glacial Acetic Acid are some other chemicals which can be absorbed and transmitted through the PTFE liner tube wall.

Generally, however, as a hydrophobic (non-wetting) material, PTFE is very resistant to the absorption of chemicals. In some cases, PTFE has superior resistance to diffusion, for example to the diffusion of automotive fuels, in comparison with all other plastics and rubbers.

Gas/Fluid Cycling

There are some applications where the fluid passing through the hose turns into a gas, then back into a fluid, then into a gas etc, in a cyclic sequence.

This is normally associated with changes in temperature and/or pressure. For complex reasons these conditions are extremely damaging to the hose liner, whatever material it is made from.

For example, hoses are sometimes used to pass steam, water, steam etc into rubber moulding presses, in order to heat the mould, then rapidly cool it before reheating in the next cycle. Hoses of all types fail rapidly in such an application and PTFE lined hoses are no exception.

Please contact Aflex Hose for further information if these conditions apply.

Connecting Assemblies for Use in Applications

The lengths of hose assemblies and their configuration in use when connected into the application must always be in accordance with the Hose Configuration information at the end of this product literature.

When being connected for use in applications, the end fittings on hose assemblies must be connected to correct mating parts in the correct way, using the correct tools, spanners, clamps, nuts and bolts etc. The connections must be sufficiently tightened to ensure that the joint is leak free but not be over tightened as this can damage the sealing surfaces, especially with PTFE lined and flared end fittings.

In applications involving the transfer through the hose of expensive or dangerous fluids or gases, the hoses and connections must be pressure tested in situ before being put in to service. This should be done with some harmless media to 1½ times the maximum working pressure of the hose assembly, as stated in the product literature.

If in doubt please contact Aflex Hose for advice.

Special Applications

Aflex Hose PTFE lined hose products are not rated as suitable for use in the following, special applications:

All Radioactive Applications involving high energy radiation, including Gamma radiation (degrades PTFE)

All Medical Implantation Applications.

All Aerospace Applications.

Bioflex and Quality Assurance, Certification and Approvals, and Hose Testing

BS EN ISO 9001:2008

Aflex products are all manufactured in accordance with BS EN ISO 9001: 2008 Quality Management Systems independently assessed and registered by National Quality Assurance Limited (NQA).

USP CLASS VI and ISO 10993-5, 6, 10 and 11 GUIDELINES

Natural and Antistatic PTFE Hose Liners, Platinum Cured Silicone Rubber Covers (White and Clear) and EPDM Rubber Cover (Blue) have been independently tested in accordance with USP protocols and are found to conform to the requirements of USP Class VI Chapter <88>.

Natural and Antistatic PTFE Hose Liners now also meet the more stringent USP Class VI and ISO 10993-6,10 and 11 guidelines at 121°C (250°F) with a “no reaction” classification.

Natural and Antistatic PTFE Hose Liners and Platinum Cured Silicone Rubber Covers (White and Clear) have also been tested in accordance with USP protocols and are found to conform to the requirements of USP Class VI <87>, the L929 MEM Elution Test and are considered non-cytotoxic.

Natural and Antistatic PTFE Hose Liners have now been further tested and have passed the more stringent USP Class VI and ISO 10993-5 guidelines at 121°C (250°F).

FDA

The Materials used to manufacture the natural PTFE Tube liner conforms to FDA 21 CFR 177.1550, and the antistatic PTFE liner conforms to FDA 21 CFR 178.3297.

3-A Sanitary Standards

The PTFE used in the liner is manufactured solely from materials which meet the requirements of the 3-A Sanitary Standards.

BPSA LEACHABLES and EXTRACTABLES TESTING

Aflex Hose Natural and Antistatic PTFE Hose Liner Tube has been independently tested in accordance with BPSA recommendations, and found to be satisfactory.

Copies of the Test Report are available for specific assessments to be made.

Pharmaceutical Manufacturers Approvals

Most of the major pharmaceutical manufacturing companies in the world have audited and/or approved Aflex Hose as a Hose Supplier.

CE Marking (Europe only)

Aflex has been assessed by Zurich Engineering and found to comply with the Pressure Equipment Directive 97/23/EC (European Community) Conformity Assessment Module D1, approved to CE Mark applicable hose products, accompanied by a Hose Usage Data Sheet, and a Declaration of Conformity.

Attestations of Conformity to ATEX Directive 94/9/EC (Potentially Explosive Atmospheres)

Available for hose and assemblies for components used in Gas Zones 1 & 2 and Dust Zones 21 & 22, when applicable.

Material Certification to EN10204

Available for all the hose or hose assembly components.

Certificates of Conformity to BS EN ISO/IEC 17050

Are available for all products.

Fuel Hose Approval to SAE J1737

Bioflex hose samples have been tested and approved to SAE J1737 for Automotive Fuel Hose applications.

Hose Testing

Each assembly is pressure tested to 1.5 times maximum working pressure before despatch, and pressure test certificates can be supplied.

How to Order Bioflex

How to Order

The quantity, hose size, liner, braid, cover, protection system, length and fittings must be selected and specified in full.

EITHER by a full, written description. The hose grade can be specified by the code initials e.g. "Bioflex AS, SS, RC, DRC-300" defines an antistatic PTFE lined hose with an EPDM rubber cover over a SS braid, with a double rubber cover at both ends.

The quantity, length and fittings can then be written in - e.g. "4 off x 1" bore Bioflex, AS, SS, RC, DRC-300 hose x 3.00 metres long. Both ends non-lined ANSI 150# S/S Flanges".

OR by Part Numbers, as defined on page 14. Example from above "4 off Part No. 16-BFX/AS-RC-00-3.00m-12-12, with DRC 300 at both ends".

Any special requirements relating to the hose construction, or information required on Tags, or Certificates, or special testing of requirements, must be specified in full on the enquiry or purchase order.

Selecting the Hose Grade

There are two types of PTFE liner available, natural (GP) and anti-static (AS) and four types of braid, Grade 304 stainless steel (SS) polypropylene (PB), Hastelloy (HB), PVDF or Kynar (KYB). These are described on page 15 & 16. Rubber covering and other external protection systems are also available, described on pages 17 and 18.

A hose grade is specified by using the abbreviations given. For example, Bioflex AS,PB would describe a hose with an anti-static PTFE liner and a polypropylene braid.

Selecting the Hose Length (see also pages 37 - 39)

Bioflex hose assemblies are made up to the specific lengths required. The hose length is taken as the length from the sealing face at one end of the hose to the same at the other end. The length tolerance is normally +5%-0%. Closer tolerances are available to special order.

*Bioflex Hose Assembly Length Limitations								
Nominal Size of Hose		*Minimum Hose Length Between Fittings				† Maximum Hose Assembly Length		
		*Used Straight		*Flexed Thru' 90°				
in	mm	in	mm	in	mm	ft	mtrs	
3/8	10	2	50	2.75	70	60	18	
1/2	15	2	50	3.15	80	60	18	
5/8	16	3	75	4.00	100	60	18	
3/4	20	3	75	4.33	110	60	18	
7/8	22	4	100	5.10	130	60	18	
1	25	4	100	6.00	150	60	18	
1 1/4	32	6	150	6.00	150	60	18	
1 3/8	35	6	150	10.00	250	60	18	
1 1/2	40	8	200	11.50	290	55	17	
1 7/8	48	8	200	16.00	400	43	13	
2	50	8	200	16.50	420	33	10	

* Listed minimum lengths are for the Bioflex Hose only, and **DO NOT INCLUDE THE LENGTHS OF THE FITTINGS AT EACH END.**

These must be found from the end fitting pages and added to calculate the minimum length of the hose assembly.

† Sizes up to 1" can be supplied in maximum lengths of up to 36 metres (120 ft) to special order.

Selecting the End Fittings

Bioflex is available with a range of 'standard' end fittings (described on pages 15-32), normally supplied hygienically PTFE lined and flared.

Stainless Steel End Fitting Materials

Non-Lined Spigots - are all made from Grade 316L SS

PTFE Lined Spigots - are all made from Grade 316L or Grade 316C SS

Cam and Groove Female Fittings - are made from Grade 316C SS (Body) and 316L SS (Spigot)

Swivelling Nuts and Flanges - are all made from Grade 304 SS

Ferrules - most ferrules are made from Grade 304 SS, except some are made from Grade 316L SS - consult Aflex Hose if necessary.

The equivalent specification for the different Grades of Stainless Steel are listed below:

Specification Equivalents List

Grade	BS - British Standard	AISI - American Standard or C = Casting Grade	EN - European Norm
316L SS	BS 316 S11	AISI 316 L	EN 1.4404
316C SS	BS 316 C16	CF8M	EN 1.4408
304 SS	BS 304 S15	AISI 304	EN 1.4301

To special order, end fitting components can be made in non-standard grades of SS such as 1.4435, or other materials such as Hastelloy or Monel.

Conditions of Sale

Bioflex hose and hose assemblies are only supplied on the basis that the customer has read and accepted the Conditions of Sale as given on page 40.

Bioflex Hose Assembly Part Number system

If required, Bioflex Hose Assembly can be defined by an individual Part Number, made up of (7) entries as below:

Hose Size	Size Part No.
3/8"	06
1/2"	08
5/8"	10
3/4"	12
7/8"	14
1"	16
1 3/8"	22
1 1/2"	24
1 7/8"	30
2"	32

Hose Type	Type Part No.
Bioflex GP (Natural PTFE Liner)	BFX/GP
Bioflex AS (Antistatic PTFE Liner)	BFX/AS

Braid and Cover	
Tube Only	TO
Stainless Steel Braid	SS
Polypropylene Braid	PB
Hastelloy Braid	HB
Kynar (PVDF) Braid	KYB
Blue EPDM Rubber Cover (on SS)	RC
Transparent Silicone Rubber (on SS)	SI
Red Fireproof EPDM Rubber (on SS)	FP
RC-300 Rubber Covered End Protection Systems (page 15) - see * Note below	

External Protection Systems	
No External Protection System	OO
SS Wire Protection Coil	PC
Rubber Anti-Scuff Rings	SR
'Safeguard' HDPE Spiral Wrap	SG
Kink Resistant	KR

Length
The overall hose length between the sealing faces at each end is given as the <u>Length Part No.</u> , either in decimal Metres followed by "m" or Inches followed by "in".

Assembled End Fitting Description *All Components in Stainless Steel	End Fitting Part No.
JIC Female	02
Fixed Male Pipe, NPT Thread	03
Fixed Male Pipe, BSPT Thread	03/B
Fixed Female Pipe, NPT Thread	06
JIC-to-NPT Male Union	08
JIC-to-Female Male Union	08F
Straight Sanitary Tri Clamp, 1.984" Diameter 0.870" Exit Diameter (Standard) 1.370" Exit Diameter (Step-Up)	10 10/S
Straight Mini Sanitary Tri Clamp, 0.984" Diameter 0.370" Exit Diameter (Standard) 1.620" Exit Diameter (Step-Up)	11 11/S
*ANSI 150# Swivelling Flange Non-Lined	12
DIN PN 10/16 Swivelling Flange Non-Lined	12/PN
*ANSI 150# Swivelling Flange, PTFE Lined	12L
DIN PN 10/16 Swivelling Flange, PTFE Lined	12L/PN
Cam and Groove, Locking Arm Swivelling Female, Non-Lined	16
Cam and Groove Locking Arm Swivelling Female, PTFE Lined	16L
Cam and Groove Male, Non-Lined	17
Cam and Groove Male, PTFE Lined	17L
DIN 11851 Female, PTFE Lined	23L
DIN 11851 Male, PTFE Lined	24L
SMS Female, PTFE Lined	26L
RJT Female, PTFE Lined	27L
BSPP Cone Seat Female	33
BSP Lug Nut Female	34

*For flange only, Carbon Steel Zinc Plated, add "/ZP" or Epoxy coated add "/EC"

Notes: ELBOWS - Elbow Fittings for all types are indicated by adding "/90°" for 90° elbows.
TRICLAMPS: For "Hot Formed" PTFE Lined Triclamps add "/HF"

Example: a 3/4" bore Bioflex GP, RC Hose Assembly with an Antistatic PTFE Liner and an outer Safeguard sleeve.
End (1) - a 3/4" ANSI 150# Swivel Flange, PTFE Lined
End (2) - a Cam and Groove Swivelling Female, PTFE Lined
Length - 4ft 6 inches
Hose Assembly Part No. = 12 - BFX/AS - RC - SG - 54in - 12L - 16L
(1) (2) (3) (4) (5) (6) (7)

ADDITIONAL REQUIREMENTS
Any additional requirements which are not included in the Part Number must be written out in full in the Order, including any special labelling or colour coding.

* **Note** - if one of the rubber end protection systems is required, for one or both ends, please define the requirement in writing in addition to the Part Number.

Bioflex Hose Liners

GP - General Purpose Liner

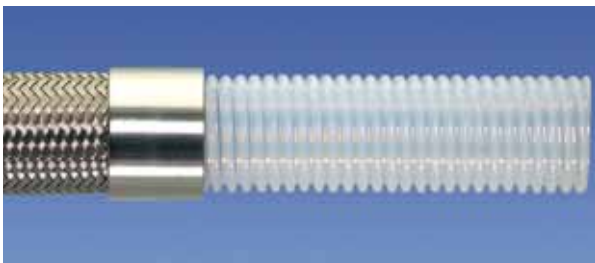

Purpose

Bioflex GP is the 'General Purpose' grade, for use in all applications where fluids or gases are being conveyed which do not generate a risk of static charge development (see "AS").

Design & Approvals

A full list of Approvals is given on Page 12.

Bioflex GP is a virgin PTFE liner, manufactured from hose grade PTFE which conforms to the requirements of:

FDA 21 CFR 177.1550

Bioflex GP hose liner tube has also been tested, and complies with **USP Class VI**, at 37°C (99°F), 70°C (158°F) and at 121°C (250°F) - see page 12.

Bioflex GP and AS PTFE Liner Tubes have also been tested for Leachables and Extractables in accordance with BPSA recommendations, and were found to be satisfactory.

EC - ELECTRICAL CONTINUITY

(Also known as "Electrically Bonded")

All Bioflex hose assemblies are electrically continuous, except Grade TO. Electrical Continuity requires that the hose assembly supplied is electrically continuous, or conductive, between metal end fittings at each end of the hose (whether GP or AS grade).

The requirements for this are specified in the German Document BRG 132 and EN ISO 8031:2009 Annex A, when tested in accordance with EN ISO 8031:2009 Clause 5, which requires that the resistance between end fittings shall be $<10^2$ ohms per assembly. For hose assemblies which meet this requirement a Grade "M" marking can be applied in accordance with EN ISO 8031:2009 Annex A if requested.

The only exception is for assemblies without braid. Grade AS, TO (Antistatic, Tube Only) meets the requirements of " Ω ", 10^3 - 10^8 ohms per assembly, but Grade GP, TO (Natural, Tube Only) does not meet either "M" or " Ω ".

AS - Anti-Static PTFE Liner



Purpose

Bioflex AS is an essential requirement in applications where there is the risk of an electrostatic charge build-up on the inside surface of the PTFE tube which may then discharge through the tube wall. Media passing through which create such a risk are fluids which have a Conductance of less than 10^{-8} S/m (Siemens per Metre), or 10^4 pS/m such as fuels, solvents, freons, some WFI (ultra-pure "Water for Injection") and non-polar organics which are being transferred at a medium to high flow velocity.

All twin or multi phase media, and any non-mixing media, such as powder in air, or water droplets in steam, in gases or in oil, also colloidal fluids constitute a particular hazard for static charge generation, and always require grade AS.

If in doubt, consult Aflex Hose.

Design & Approval

Bioflex AS is an anti-static PTFE liner manufactured from FDA 21 CFR 177.1550 approved PTFE, and less than 2.5% of "high purity" Carbon Black material to FDA requirement 21 CFR 178.3297. The carbon is encapsulated by the PTFE, and in normal, non-abrasive applications will not come loose to contaminate any fluid passing through. Leachables and Extractables testing confirmed that no carbon was found.

A typical example involves cleaning systems which create a twin phase mixture passing through the hose a high velocity, such as WFI water purged out with air or nitrogen.

Bioflex AS also conforms to **USP Class VI**, at 37°C (99°F), 70°C (158°F) and at 121°C (250°F) - see page 12.

Antistatic Hose Assemblies

When "AS" (Antistatic) grade hose is specified, then the hose or hose assembly supplied will be tested in accordance with EN ISO 8031:2009 Clause 7 using electrodes specified in EN ISO 8031:2009 Clause 4.2.2.2 d) (and Clause 4.2.2.2 e) if the hose has an antistatic cover) and meet the Antistatic requirements of EN ISO 8031:2009 Annex A. This requires, for an antistatic liner or antistatic cover, that the resistance between an appropriately placed foam electrode and a metallic end fitting will be between 10^3 to 10^8 ohms per assembly. For hose assemblies which meet these requirements an appropriate Grade " Ω " marking can be applied in accordance with EN ISO 8031:2009 Annex A if requested.

NOTE: When in service, at least one end fitting must be connected to earth, to permit dissipation of the static charge from the end fitting.

Bioflex Hose Braids

SS - Stainless Steel Braid

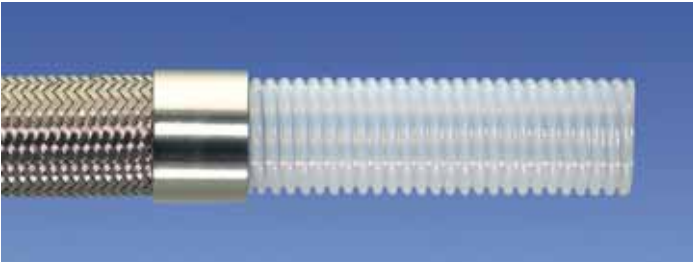

Purpose

Stainless Steel braided hose is the general purpose product, and can be used in applications involving high temperatures and working pressures. High tensile AISI 304L stainless steel wire is used, to give maximum pressure resistance and external protection to the hose.

PB - Polypropylene Braid

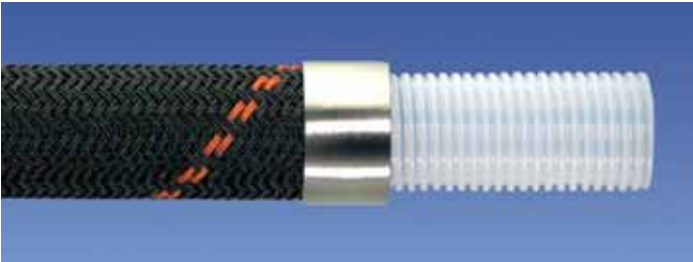

Purpose

Polypropylene braided hose is often preferred to SS in applications involving frequent handling and movement of the hose, and where temperatures are within the range -30°C and $+100^{\circ}\text{C}$ (-22°F to $+212^{\circ}\text{F}$). PB braid is lighter in weight, and any broken strands will not cut the operator's hands. In addition, PB braid is not prone to "chloride stress corrosion", and has generally good chemical resistance.

To ensure *Electrical Continuity between end fittings 2 strands of Monel wire earthing strips are criss-crossed on to the liner, underneath the Polypropylene Braid. These are folded back underneath the ferrule at both end fittings, to make an electrical contact.

NOTE: Prolonged exposure to sunlight eventually results in UV degradation of PB braid.

TO - Tube Only (no braid)



Purpose

TO grade hose (available in both GP and AS) is a lightweight hose, used in applications where working pressures are low and where there is no need for the physical protection offered by an external braid. TO grade tube is fully vacuum proof up to 212°F . TO grade hose assemblies are not Electrically Continuous ('EC').

HB - Hastelloy Braid (C276 grade)



Purpose

Hastelloy Wire Braid is used instead of SS where severe chemical corrosion conditions exist around the outside of the hose. One way in which this can happen is when Chlorine or Fluorine are being transferred. Diffusion of trace quantities of such gases through the PTFE liner can lead to atmospherically wetted fluorine or chlorine attacking the braid material, in which case the Hastelloy Braid would be resistant.

Specifications

Same as for SS on Pages 9 and 10, except the Burst Pressures and the Maximum Working Pressures are both reduced to 50% of the SS pressures listed.

KYB - Kynar Braid (Polyvinylidene Fluoride Monofilament)

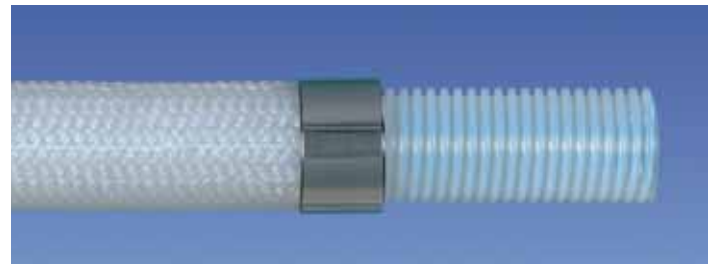

Purpose

Kynar Braid is used for the same reasons as HB above, but only in applications where the reduced pressure and temperature ratings of KYB as listed are acceptable.

Electrical Continuity is ensured by using the same design as for Bioflex PB.

Bioflex Rubber Covers

RC - Rubber Covered



Purpose

For the most rugged applications where the hose may be subjected to rough treatment and severe external abrasion. Also for hygienic applications, where the external smoothness and cleanability of the hose is of prime importance.

Design

An SS braided hose assembly has a smooth finish, blue EPDM external rubber cover extruded over and vulcanised directly onto the braid. EPDM has excellent chemical resistance, and the hose has a temperature range from -40°C, -40°F up to +140°C, +284°F (internal fluid) or +120°C, +248°F (external temperature). Black anti-static EPDM, and alternative colours of rubber, and strips with alternative text titles are available to special order.

Specifications

The Blue EPDM rubber cover has been tested and conforms to the requirements of USP Class VI.

SI - Silicone Rubber Cover

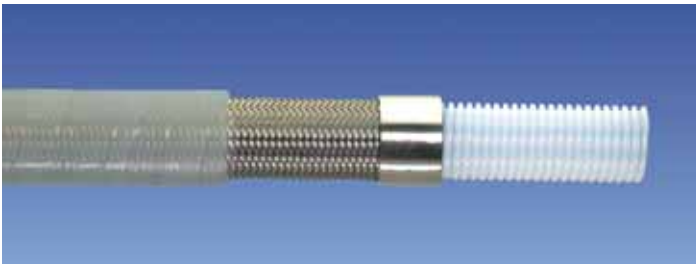

Purpose

As for RC hose, but where the hose may be required to withstand temperatures from -73°C, -100°F up to +204°C, +400°F. SI grade hose is semi-transparent, allowing visual monitoring of the braid, with a very smooth external surface finish.

Design

An SS braided hose assembly has a platinum cured silicone rubber cover extruded directly onto the braid, with a very smooth external surface finish.

Specifications

The Silicone rubber cover has been tested and conforms to the requirements of USP Class VI.

FP - Fireproof Rubber Covered



Purpose

As for RC hose, but where the hose is also required to resist failure in the event of fire, in accordance with Specification BS5173 Section 103.13 part 6.3 (Fireproof). This specification calls for an 1100°C (2012°F) flame to be applied to the hose at minimum bend radius, maximum operating pressure (water), and one end fitting under vibration. The hose must withstand at least 15 minutes without leakage.

Design

As for RC hose, but the red EPDM rubber is specially compounded to be fire resistant. Black, anti-static EPDM Fireproof rubber is also available as an option to special order.

RC-300 - Rubber Covered 300mm End Protection



Purpose

In applications where excessive flexing of the hose at the end fitting occurs, it is sometimes necessary to 'stiffen' the hose in this area, to prevent kinking.

Design

A layer of rubber is applied and vulcanised directly to the ferrule, and 300mm (12 inch) along the hose from the fitting. This can be done either on an SS braided hose (RC-300) or on a rubber covered hose as a 300mm (12 inch) long double layer of rubber at the end (DRC-300).

The rubber used is normally Blue EPDM, but if the hose is FP, or SI covered, then the same type and colour of rubber would be used (DFP-300 or DSI-300).

Limitations

Cannot be applied to PB or KYB braided hose. If required for a PB hose, consult Aflex Hose for an alternative "EPR" system. (EPR includes a 300mm (12 inch) length of loose rubber hose jubilee clipped to the ferrule).

Bioflex External Protection Systems

KR - Kink Resistant



Purpose

For applications where there is a risk that the hose might be severely flexed anywhere along its length, and possibly kinked as a result. **NOTE:** The rubber cover hose has a "cloth" finish, not the very smooth finish normally available.

Design

KR is only available on hoses which also have a SS wire braid and a rubber cover (RC, FP or SI). An SS reinforcement wire is helically wound on to the SS wire braid, then the rubber cover is applied on top of the helical wire.

Limitations

Only available for sizes 1/2" and above. Specifications as for the relevant RC or SI hose grade on pages 10 & 11.

SG - Safeguard Protection Sleeve

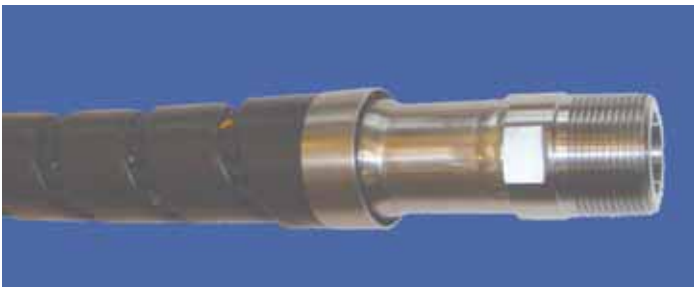

Purpose

To protect the hose against external abrasion and mechanical damage. For use in applications where maximum external protection is required with minimum extra hose weight. Particularly useful with PB or KYB hose, where a rubber cover is not an option.

Design

A lightweight black, HDPE (High Density Poly Ethylene) strip spirally wound around the outside of the hose over its whole length, secured to each end fitting by crimping under a SS ferrule.

Limitations

Safeguard is applicable to all hose types and all hose sizes from 1/2" up to 4".

Safeguard is limited to use within a temperature range from -40°C (-40°F) up to +100°F (212°F). Internal fluid temperatures up to 120°C (250°F) are acceptable, when external temperatures are ambient.

Other hose usage limitation specifications are not altered by the addition of Safeguard.

SR - Scuff Rings

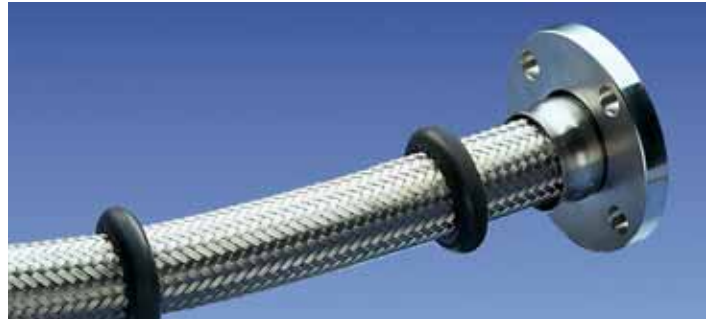

Purpose

For medium duty applications where the hose requires some protection against abrasion when dragged over the ground, but where a full rubber cover would be too heavy and cumbersome. Also for PB and KYB braided hose, which cannot be Rubber Covered.

Design

Specially moulded abrasion resistant rubber scuff rings are placed every half metre along the hose.

Limitations

Available for hose sizes 1" (25mm) to 2" (50mm) only. The operating temperature should not exceed 140°C (284°F) (internal).

PC - Protection Coil

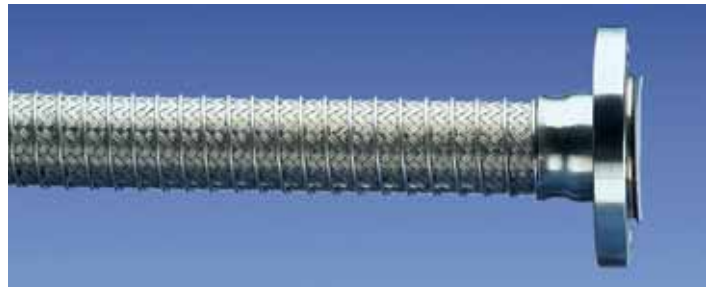

Purpose

For applications where the hose requires protection against abrasion when dragged over the ground, but where any rubber reinforcement is not permissible due to temperature, chemicals etc.

Design

A stainless steel wire helix is wound onto the braid and welded to the ferrules at each end.

Limitations

Available for all sizes and Grades of Bioflex Hose.

Specifications

As for the relevant Hose Grade.

Bioflex Non Lined Swivel Flange Fittings

Flange Specification

- ANSI B16.5 (also ASME B16.5) Class 150# and 300#
- *DIN PN10, PN16 and PN40
- JIS 10K
- Other Pressure Ratings and Flange Specifications are also available.

*DIN PN10, PN16 and PN40 Flanges all have the same dimensions, and so are fully interchangeable.

Maximum Pressure Ratings for Flange Fittings

- ANSI 150# = 16 Bar (230 psi), ANSI 300# = 32 Bar (460 psi)
- DN PN10 = 10 Bar (145 psi), DN PN16 = 16 Bar (230 psi)
- PN40 = 40 Bar (580 psi)



End Fitting Materials

- Flanges in Grade 304 SS
- Flange Retainers in Grade 316L SS
- Ferrules, most in Grade 304 SS, some sizes in Grade 316 SS

Alternative Options for Flange Component only:

- Zinc Plated Carbon Steel
- Blue Epoxy Coated Carbon Steel

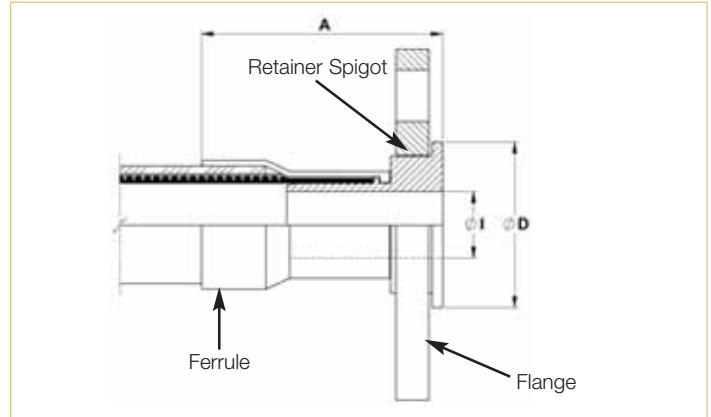

Nominal Hose Size		*Fitting Length A (Bioflex RC)		Flared Diameter D				Fitting Inside Diameter I	
				ASA150		PN10/16			
in	mm	in	mm	in	mm	in	mm	in	mm
1/2	13	2.79	71.0	1.38	35.0	1.77	45.0	0.38	9.53
3/4	20	3.15	80.0	1.69	42.9	2.28	58.0	0.63	15.88
1	25	3.27	83.0	2.00	50.8	2.68	68.0	0.79	20.24
1 1/2	40	4.10	104.0	2.88	73.0	3.47	88.0	1.25	31.75
2	50	4.17	106.0	3.63	92.0	4.02	102.0	1.75	44.45

*Fitting Lengths listed are for Bioflex RC, SI and FP hose grades. Shorter lengths apply for other hose grades.

Bioflex Integral PTFE Lined Flange Fittings & "Step-Up" Design

Flange Specification

- ANSI B16.5 (also ASME B16.5) Class 150# and 300#
- *DIN PN10, PN16 and PN40
- JIS 10K
- Other Pressure Ratings and Flange Specifications are also available.

*DIN PN10, PN16 and PN40 Flanges all have the same dimensions, and so are fully interchangeable.

Maximum Pressure Ratings for Flange Fittings

- ANSI 150# = 16 Bar (230 psi), ANSI 300# = 32 Bar (460 psi)
- DN PN10 = 10 Bar (145 psi), DN PN16 = 16 Bar (230 psi)
- PN40 = 40 Bar (580 psi)

End Fitting Materials

- Flanges in Grade 304 SS
- Flange Retainers in Grade 316L SS
- Ferrules, most in Grade 304 SS, some sizes in Grade 316L SS

Alternative options for Flange component only:

- Zinc Plated Carbon Steel
- Blue Epoxy Coated Carbon Steel.

90° Elbow Flange Fittings

90° Elbow Integral PTFE lined Flange Fittings are available for sizes 1", 1 1/2" and 2" - see page 33.

integral PTFE Lined Swivel Flange Fittings

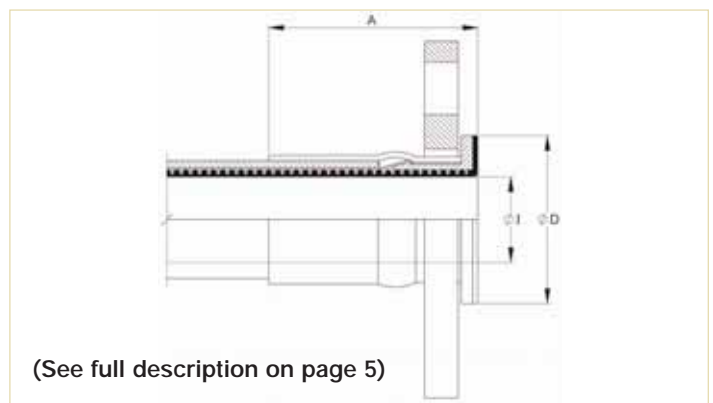

(See full description on page 5)

Nominal Hose Size		*Fitting Length A (Bioflex RC)		Flared Diameter D				Fitting Inside Dia. and Hose Bore I		Recommended Bolt Tightening Torques	
				ANSI 150#		DIN PN10/16					
in	mm	in	mm	in	mm	in	mm	in	mm	ft.lbs	mtr. kgs
1/2	13	1.850	47.0	1.25	32	1.25	32	1/2	12.7	8	1.10
3/4	20	1.890	48.0	1.690	43	1.69	43	3/4	19.0	8	1.10
1	25	2.400	61.0	2.00	50	2.50	63	1	25.4	10	1.40
1 1/2	40	2.360	60.0	2.875	73	3.50	88	1 1/2	38.0	15	2.10
2	50	2.720	69.0	3.625	92	4.00	102	2	50.8	25	3.50

*Fitting Lengths listed are for Bioflex RC, SI and FP hose grades. Shorter lengths apply for other hose grades.

* "Step-Up" PTFE Lined Flange Fitting Design for Bioflex Hose

Example: a 2" hose to 3" ANSI 150# PTFE Lined Flange Joint

Because Bioflex Hose has better flow rates than some larger bore sizes of Convolute PTFE hose, it represents a superior alternative when fitted with the larger size flanges in some applications.

It is, however, necessary to also "Step-Up" the PTFE-lined bore, to ensure a diameter match with the mating connector.

This is best achieved using a solid PTFE Adaptor Plate, as shown in the drawing.

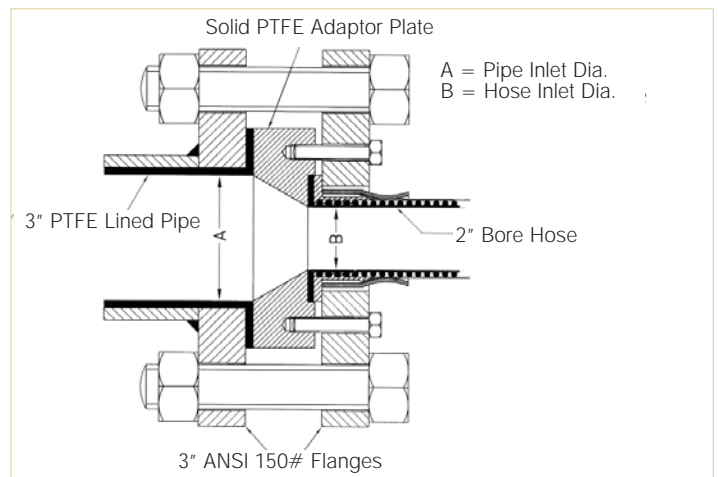

Bioflex Female Cam & Groove Fittings PTFE Lined and Non-Lined

End Fitting Specification

- Generally in accordance with A-A-59326 (replaces MIL-C-27487) and EN14420-7:2004 (replaces DIN 2828), and all are fully interchangeable.

Temperature and Pressure Ratings

- All sizes up to 16 Bar (230 psi)
- Up to 100°C (212°F) Buna N Gasket or 200°C (400°F) FEP Gasket.

End Fitting Materials

- Spigot in Grade 316L SS
- Body in Grade 316C SS
- Ferrules, most in Grade 304 SS, some sizes in Grade 316L SS
- Standard Gasket is Buna N (Nitrile) Rubber.
- FEP encapsulated Silicone Rubber Gaskets also available.

90° Elbow Cam & Groove Fittings (LINED ONLY)

90° Elbow Integral PTFE lined Cam & Groove Fittings are available for sizes 1", 1 1/2" and 2" - see page 33.

Swivelling, Locking Arm Female Cam and Groove Fittings - Non Lined

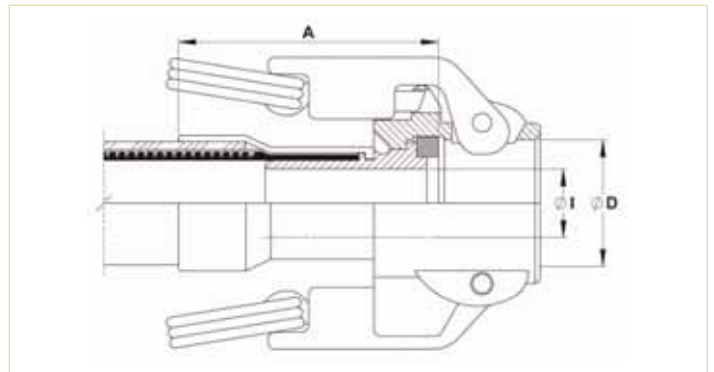

Nominal Hose Size		*Fitting Length A (Bioflex RC)		Cam Sleeve Inside Diameter D		Fitting Inside Diameter I	
in	mm	in	mm	in	mm	in	mm
3/4	20	3.22	82.0	1.260	32	0.625	15.88
1	25	3.39	86.5	1.456	37	0.797	20.24
1 1/2	40	3.97	101.0	2.126	54	1.25	31.75
2	50	4.09	104.0	2.520	64	1.75	44.45

Fixed or Swivelling, Locking Arm Female Cam and Groove Fitting - Integral PTFE Lined

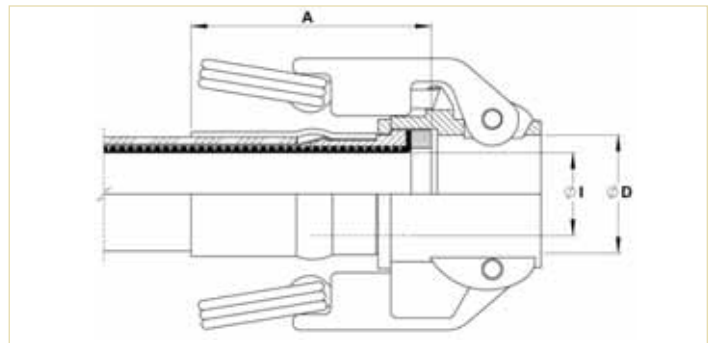

Nominal Hose Size		*Fitting Length A (Bioflex RC)		Cam Sleeve Inside Diameter D		Fitting Inside Diameter I	
in	mm	in	mm	in	mm	in	mm
3/4	20	2.155	54.75	1.260	32.0	0.75	19.0
1	25	2.716	69.00	1.456	37.0	1.00	25.0
1 1/2	40	2.612	66.35	2.126	54.0	1.50	38.0
2	50	2.966	75.35	2.520	64.0	2.00	50.0

*Fitting Lengths listed are for Bioflex RC, SI and FP hose grades. Shorter lengths apply for other hose grades.

Bioflex Male Cam & Groove Fittings, PTFE Lined & Non-Lined and Lined Flange Adaptors

PTFE Lined or Non-Lined Male Cam and Groove Fittings

End Fitting Specification

- Generally in accordance with A-A-59326 (replaces MIL-C-27487) and EN14420-7:2004 (replaces DIN 2828), and all are fully interchangeable.

Temperature and Pressure Ratings

- Temperature determined by the type of gasket in the Female connecting component.
- Pressures up to 16 Bar (230 psi)



PTFE Lined Male Fitting

End Fitting Materials

- Fittings in Grade 316L SS
- Ferrules, most in Grade 304 SS, some sizes in Grade 316L SS
- Adaptor Flange Only in Grade 304 SS

Integral PTFE Lined Cam & Groove Male Fitting

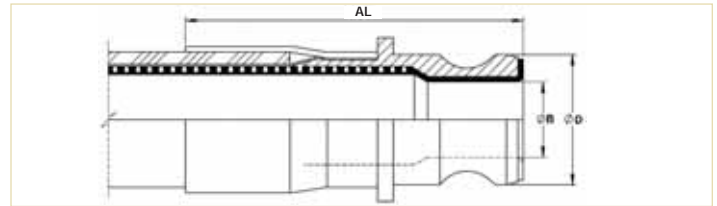

Non-Lined Cam & Groove Male Fitting

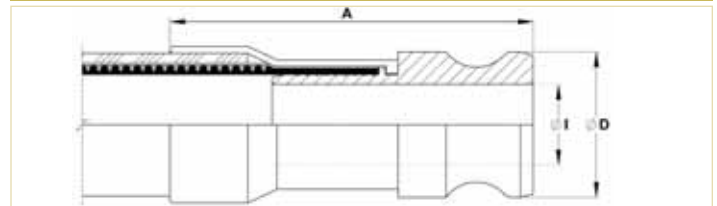

Nominal Hose Size		Outside Diameter D		Non-Lined Fitting Length A		Non-Lined Inside Diameter I		PTFE Lined Fitting Length AL		PTFE Lined Inside Diameter B	
in	mm	in	mm	in	mm	in	mm	in	mm	in	mm
3/4	20	1.260	32.0	3.48	88.5	0.625	15.88	2.82	71.58	0.71	18.13
1	25	1.456	37.0	3.94	100	0.80	20.24	3.74	95.00	0.81	20.61
1 1/2	40	2.106	53.5	4.86	123.5	1.25	31.75	3.98	101.00	1.35	34.40
2	50	2.480	63.0	5.47	139	1.75	44.45	4.61	117.00	1.72	43.75

*Fitting Lengths listed are for Bioflex RC, SI and FP hose grades. Shorter lengths apply for other hose grades.

PTFE LINED MALE CAM and GROOVE X FLANGE ADAPTORS

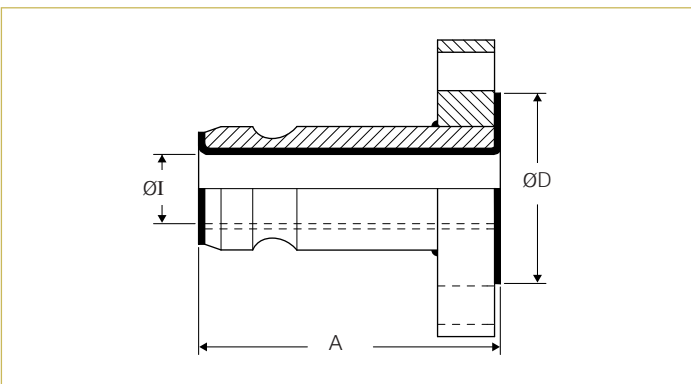

Note: Other Flange Specifications and Pressure Ratings are also available. Non-Lined adaptors and Female Cam and Groove X Flange Adaptors are also available, to special order.



Cam Action Adaptor Size		Flange Size & Specification	ØD		A		I	
in	mm		in	mm	in	mm	in	mm
1	25	1" ANSI 1507	2.00	50	4 1/8	105	0.84	21
1	25	DN25/PN16	2.58	64	4 1/8	105	0.84	21
1 1/2	40	1 1/2" ANSI 1507	2.87	73	4 3/8	118	1.35	34
1 1/2	40	DN40/PN16	3.47	88	4 3/8	118	1.35	34
2	50	2" ANSI 1507	3.63	92	4 3/8	118	1.69	43
2	50	DN50/PN16	4.00	102	4 3/8	118	1.69	43

Bioflex Mini-Sanitary and Sanitary Triclover Fittings, PTFE Lined

End Fitting Specification

- BS4825 Pt 3 (UK)
- ASME BPE-a-2007 (USA)
- DIN32676 (Europe, DN Sizes)
- ISO 1127 (Europe) (Non Standard, Specials Only)

Temperature and Pressure Ratings

- Pressures up to 16 Bar (230 psi)
- Temperatures up to 120°C (250°F)
- Higher Pressures & Temperatures possible with Special Clamps and Rubber Seals.

End Fitting Materials

- Fittings in Grade 316L SS (= BS 316 S11 = EN 1.4404)
- Ferrules, most in Grade 304 SS, some sizes in Grade 316L SS

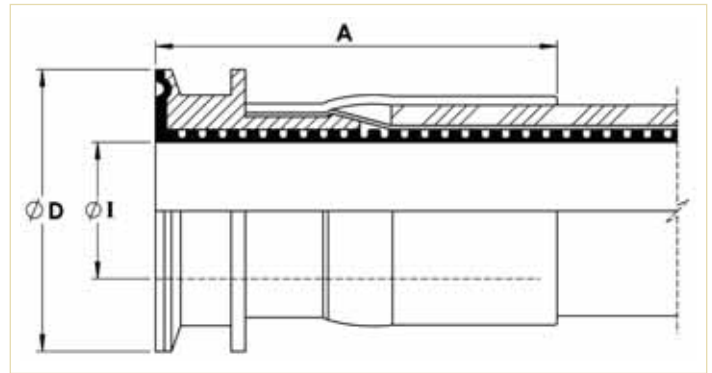

Nominal Hose Size		Nominal Pipe Size	Flange Diameter D		Outlet Diameter I		*Fitting Length A (Bioflex RC)	
in	mm		in	mm	in	mm	in	mm
3/8	10	1/2"	0.984	25.0	3/8	9.5	2.20	56
1/2	13	1/2"	0.984	25.0	3/8	9.0	2.36	60
5/8	16	DN15	1.340	34.0	5/8	16.0	2.48	63
3/4	20	DN20	1.340	34.0	3/4	19.0	2.56	65
3/4	20	3/4"	1.984	50.5	3/4	19.0	2.56	65
7/8	22	1"	1.984	50.5	7/8	22.2	2.60	66
1	25	DN25	1.984	50.5	1	26.0	2.84	72
1 3/8	35	1 1/2"	1.984	50.5	1 3/8"	34.9	2.84	72
1 1/2	40	1 1/2"	1.984	50.5	1 3/8"	34.5	3.15	80
1 1/2	40	2"	2.521	64.0	1 1/2"	38.0	3.15	80
1 7/8	48	2"	2.521	64.0	1 7/8"	47.6	3.31	84
2	50	2"	2.521	64.0	1 7/8"	47.8	3.58	91

Note: The 3/8", 5/8", 7/8", 1 3/8" and 1 7/8" hose sizes can only be supplied as assemblies with lined Triclover (or I-Lined fittings) at BOTH ends, because other types of fittings (Flanges, Camlocks etc.) are not available for these sizes of hose.

*Fitting Lengths listed are for Bioflex RC, SI and FP hose grades. Shorter lengths apply for other hose grades.

Bioflex Sanitary Triclover Fittings, PTFE Lined and "Beaded"

End Fitting Specification

- BS4825 Pt 3 (UK)
- ASME BPE-a-2007 (USA)
- DIN32676 (Europe, DN Sizes)
- ISO 1127 (Europe) (Non Standard, Specials Only)

End Fitting Materials

- Fittings in Grade 316L SS (= BS 316 S11 = EN 1.4404)
- Ferrules, most in Grade 304 SS, some sizes in Grade 316L SS

Temperature and Pressure Ratings

- Pressures up to 16 Bar (230 psi)
- Temperatures up to 180°C (356°F)
- Higher Pressures possible with Special Clamps.

Description

In this new design, the PTFE hose liner tube is extended through the Triclover end fitting and is flared over the sealing face. It is then hot-formed to conform to the shape of the rubber seal and therefore replaces the rubber seal.

This includes the 'bead' shape which is used for concentric location of the seal to the mating components when a joint is made as shown in the drawing.

Advantages of the Bioflex PTFE Beaded End Fitting

- After connection, the PTFE does not 'bulge' into the bore in the same way that a rubber seal would. This rubber bulge interferes with the flow path and can cause material entrapment but these problems are eliminated by using the new design.
- The need to ensure the compatibility of the rubber seal with the media passing through is no longer a problem, due to the all PTFE sealing system.
- The joint includes only one sealing face not 2 as with the rubber seal.
- The internal section of the moulded PTFE seal, which is squared off to provide a closed sealing edge in the joint, ensure no crevices in which material entrapment might occur.
- If hoses are required to be joined together then the Bioflex PTFE Beaded Triclover End Fitting can be connected to a standard Bioflex Triclover Fitting to provide an all PTFE joint between the hoses.

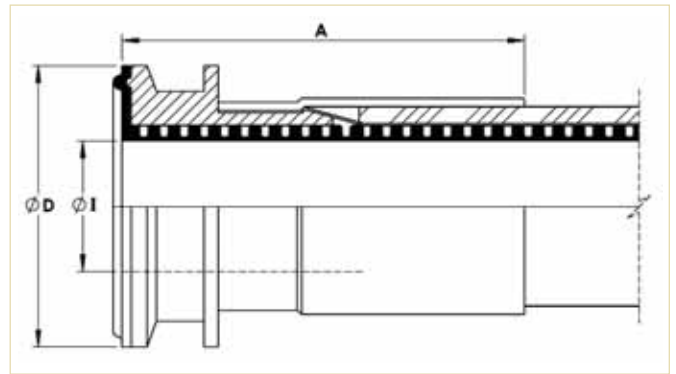

Nominal Hose Size		Nominal Pipe Size	Flange Diameter D		Outlet Diameter I		*Fitting Length A (Bioflex RC)	
in	mm		in	mm	in	mm	in	mm
3/4	20	DN20	1.340	34.0	3/4	19.0	2.56	65
7/8	22	1"	1.984	50.5	7/8	22.2	2.60	66
1	25	DN25	1.984	50.5	1	26.0	2.84	72
1 3/8	35	1 3/4"	1.984	50.5	1 3/8	34.9	2.84	72
1 7/8	48	2"	2.521	64.0	1 7/8	47.6	3.31	84

*Fitting Lengths listed are for Bioflex RC, SI and FP hose grades. Shorter lengths apply for other hose grades.

Bioflex Mini-Sanitary and Sanitary Triclover Fittings - Not PTFE Lined



End Fitting Specification

- BS4825 Pt 3 (UK)
- ASME BPE-a-2007 (USA)
- DIN32676 (Europe, DN Sizes)
- ISO 1127 (Europe) (Non Standard, Specials Only)

Temperature and Pressure Ratings

For Standard Clamp and Standard (EPDM) Gasket

- Pressures up to 16 Bar (230 psi)
- Temperatures up to 120°C (250°F)
- Higher Pressures and Temperatures with Special Clamps and Gaskets.

End Fitting Materials

- Fittings in AISI 316L = EN 1.4404 = BS 316 S11. Internal Bores all Electropolished to $<15\mu\text{m Ra}$ ($<0.375\mu\text{mtr}$).
- Ferrules, most in Grade 304 SS, some sizes in Grade 316L SS

Outlet Diameters (Inch pipe sizes only)

The outlet diameters as listed are in accordance with BS4825. The ASME specification, however, requires these diameters to be 0.005" (0.125mm) less in each case. An Outlet Diameter tolerance of +0.000 -0.005" has therefore been applied, so that the same fitting satisfies requirements of both specifications.

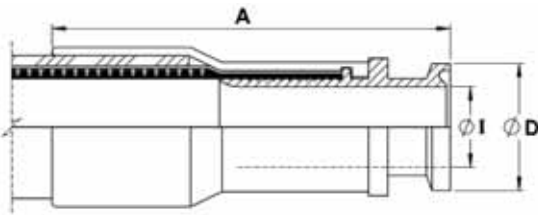

MINI-SANITARY TRICLAMP (TRICLOVER) FITTINGS

Nominal Hose Size	Nominal Pipe Size	*Fitting Length A		Flange Dia. D		*Outlet Dia. I	
		in	mm	in	mm	in	mm
1/2"	1/2" & DN10	2.8	72	0.984	25.0	3/8	9.5
1/2"	3/4"	2.8	72	0.984	25.0	5/8	16.0
3/4"	3/4"	3.1	79	0.984	25.0	5/8	16.0

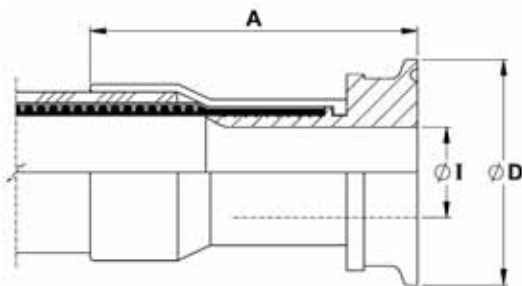

SANITARY TRICLAMP (TRICLOVER) FITTINGS

Nominal Hose Size	Nominal Pipe Size	*Fitting Length A		Flange Dia. D		*Outlet Dia. I	
		in	mm	in	mm	in	mm
1/2"	1"	2.7	69	1.984	50.5	7/8	22.2
3/4"	DN15	3.0	77	1.156	34.0	5/8	16.0
3/4"	ISO (DN) 15	3.0	77	1.984	50.5	0.713	18.10
3/4"	ISO (DN) 20	3.0	77	1.984	50.5	0.934	23.7
1"	1"	3.2	82	1.984	50.5	7/8	22.2
1"	DN25	3.2	82	1.984	50.5	1	26.0
1"	ISO (DN) 25	3.2	82	1.984	50.5	1.170	29.7
1"	1 1/2"	3.2	82	1.984	50.5	1 3/8"	34.9
1 1/2"	1 1/2"	3.9	98	1.984	50.5	1 3/8"	34.9
1 1/2"	DN40	3.9	98	1.984	50.5	1 1/2"	38.0
2"	2"	4.1	103	2.516	64.0	1 7/8"	47.6
2	DN50	4.1	103	2.516	64.0	1.975	50.0
2"	2 1/2"	4.3	110	3.047	77.5	2 3/8"	60.3
2"	DN65	4.3	110	3.047	77.5	2.600	66.0
2"	3"	4.3	110	3.5799	1.0	2 7/8"	73.0
2"	DN80	4.3	110	4.176	106.0	3.191	81.0

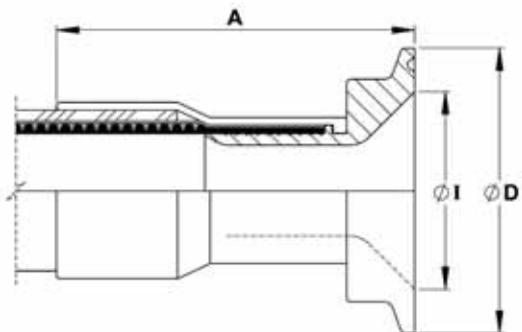

*Fitting lengths listed are for Bioflex RC, SI and FP Grades. Shorter lengths apply for other grades of Bioflex

Bioflex 90° Elbow Triclover Fittings (90° Elbow Mini-Sanitary & Sanitary Triclamp Fittings)

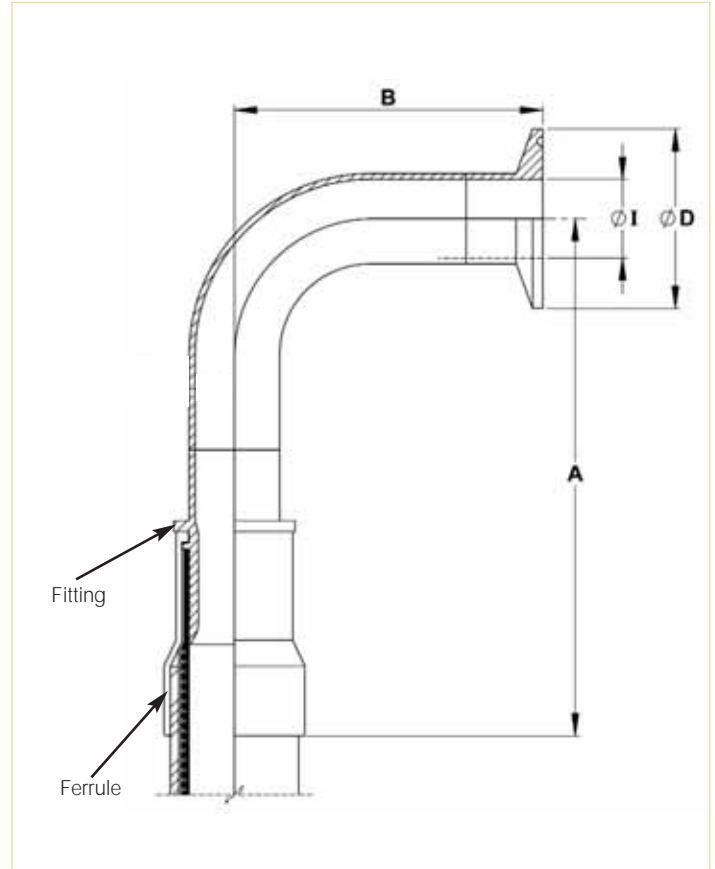

End Fitting Specification

- BS4825 Pt 3
- ASME-BPE-a-2007
- Others to Special Order

Temperature and Pressure Ratings

For Standard Clamp and Standard (EPDM) Gasket

- Pressures up to 16 Bar (230 psi)
- Temperatures up to 120°C (250°F)
- Higher Pressures and Temperatures with Special Clamps and Gaskets.

End Fitting Materials

- Fittings in Grade AISI 316L = EN 1.4404 = BS 316 S11
- Internal Bore average 15µin Ra, Electropolished if required
- Ferrules, most in Grade 304 SS, some sizes in Grade 316L SS

Outlet Diameters

The outlet diameters as listed are in accordance with BS4825. The ASME specification, however, requires these diameters to be 0.005" (0.125mm) less in each case. An Outlet Diameter tolerance of +0.000 -0.005" has therefore been applied, so that the same fitting satisfies requirements of both specifications.

Nominal Hose Size		*Centre Line To Fitting End A (Bioflex RC)		Centre Line to Face B		Flange Diameter D		*Outlet Diameter I	
in	mm	in	mm	in	mm	in	mm	in	mm
1/2	13	5.78	147	1.60	41.0	0.984	25.0	3/8	9.5
3/4	20	6.41	163	1.60	41.0	0.984	25.0	5/8	16.0
1	25	6.53	166	2.00	51.0	1.984	50.5	7/8	22.2
1 1/2	40	7.99	203	2.75	70.0	1.984	50.5	1 3/8	34.9
2	50	9.33	237	3.50	88.9	2.16	64.0	1 7/8	47.6

*Fitting lengths listed are for Bioflex RC, SI and FP Grades. Shorter lengths apply for other grades of Bioflex

Bioflex DIN11851 Male & Female Fittings, PTFE Lined, and Female Fittings, Non-Lined

Description

DIN11851 male and female fittings, integral PTFE lined and flared. The PTFE sealing face is hot moulded into the correct shape, designed to achieve the optimum pressure seal. 90° elbow PTFE lined fittings are available for some sizes and grades - see page 33.

Specification

- Generally to German DIN 11851 specifications.

NB: The PTFE lined male fitting is designed to be used without a rubber seal. Please note that when connecting to a PTFE Lined DIN 11851 Male, extra spanner tightening of the nut is sometimes required in order to provide a leak free connection.

Fitting Materials

- Spigots in Grade 316L SS (Non-Lined Spigot in 1.4571)
- Nuts in Grade 304 SS
- Ferrules, most in Grade 304 SS, some sizes in Grade 316L SS

Temperature & Pressure Ratings

- Sizes up to 1 1/4" MWP = 40 Bar (580 psi) up to 130°C (266°F)
- Sizes 1 1/2" & 2" MWP = 25 Bar (360 psi) up to 130°C (266°F)

Except where the applicable hose pressure/temperature ratings are lower (page 8).

DIN11851 MALE & FEMALE FITTINGS, PTFE LINED



PTFE Lined DIN11851 Male Fitting



PTFE Lined DIN11851 Female Fitting

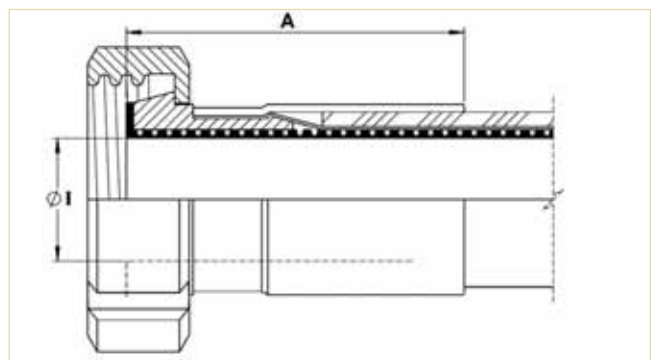
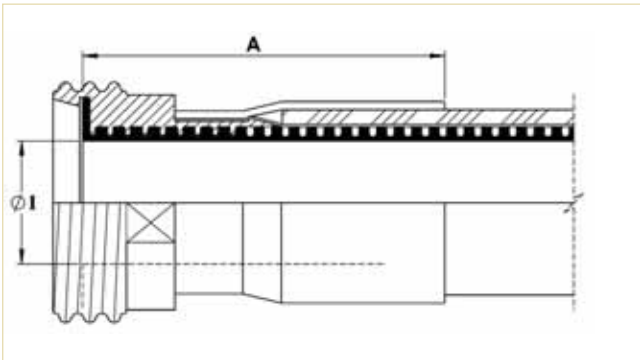

Nominal Hose Size = 'I' Dia.		*Male Fitting Length A (M) (Bioflex RC)		*Female Fitting Length A (F) (Bioflex RC)	
in	mm	in	mm	in	mm
1/2	15	2.28	58	2.00	51
3/4	20	2.44	62	2.17	55
1	25	3.00	76	2.75	70
1 1/4	32	2.75	70	2.50	64
1 1/2	40	2.84	72	3.00	76
2	50	3.47	88	3.55	90

DIN11851 FEMALE FITTING, NON-LINED

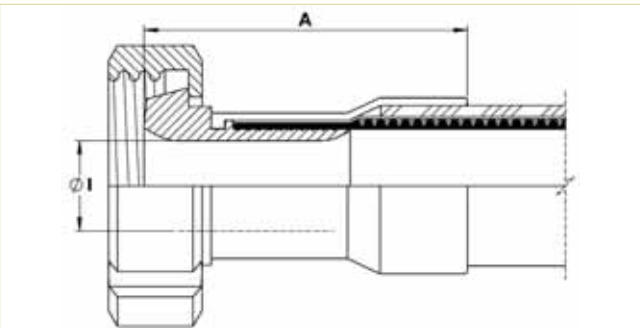

Nominal Hose Size		I Diameters		*Fitting Length A	
in	mm	in	mm	in	mm
1/2	15	0.375	9.5	2.58	65
3/4	20	0.625	15.9	3.00	76
1	25	0.797	20.2	3.20	81
1 1/4	32	1.030	26.2	3.82	97
1 1/2	40	1.250	31.8	3.82	97
2	50	1.750	44.5	3.94	100

*Fitting lengths listed are for Bioflex RC, SI and FP Grades. Shorter lengths apply for other grades of Bioflex

Bioflex SMS Female Fittings - PTFE Lined, RJT Female Fittings - Non Lined

End Fitting Specification

- SMS generally to Swedish SMS1148 specification.
- RJT generally to British BS4825 Pt 5 specification.

Temperature and Pressure Ratings

- Pressures up to 10 Bar (150 psi)
- Temperatures up to 150°C (302°F)

End Fitting Materials

- Spigots in Grade 316L SS
- Nuts in Grade 304 SS
- Ferrules, most in Grade 304 SS, some sizes in Grade 316L SS

90° Elbows

PTFE Lined 90° elbow fittings are available for some sizes and grades - see page 33.

SMS FEMALE FITTING, PTFE LINED

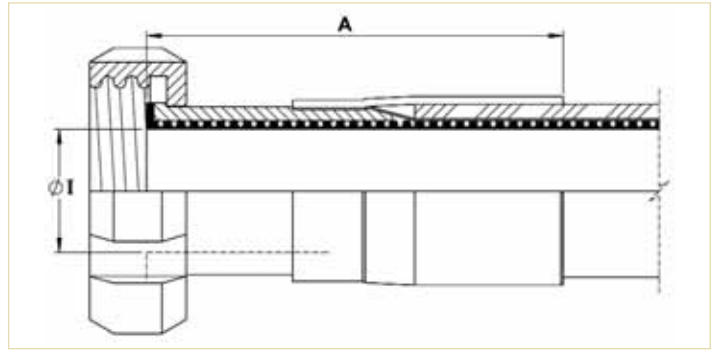

Nominal Hose Size		*Fitting Length A (Bioflex RC)		Fitting Inside Diameter I	
in	mm	in	mm	in	mm
1	25	3.39	86	1	25.4
1 ¹ / ₄	32	3.39	86	1 ¹ / ₄	32.0
1 ¹ / ₂	40	3.70	94	1 ¹ / ₂	38.0
2	50	4.10	104	2	50.8

RJT FEMALE FITTING, NON LINED

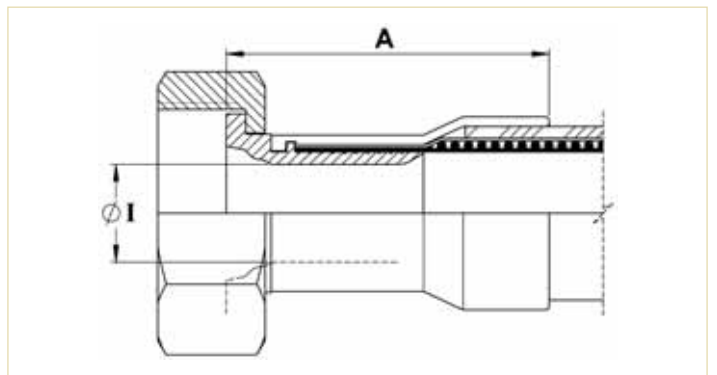

Nominal Hose Size		*Fitting Length A (Bioflex RC)		Fitting Inside Diameter I	
in	mm	in	mm	in	mm
1	25	2.95	75	0.80	20.24
1 ¹ / ₂	40	3.58	91	1.25	31.75
2	50	3.66	93	1.75	44.45

*Fitting lengths listed are for Bioflex RC, SI and FP Grades. Shorter lengths apply for other grades of Bioflex

Bioflex NPT and BSPT Fixed Male and NPT Fixed Female Fittings

End Fitting Specification

- NPT Taper Threads to American National Standard Pipe Taper Thread design to ANSI B2.1
- BSPT Threads to British Standard Pipe Taper Thread design to BS21
- Alternatives - Parallel Threads, Metric Threads and Others.

End Fitting Materials

- Fittings in Grade 316L SS
- Ferrules, most in Grade 304 SS, some sizes in Grade 316L SS

Alternatives - Fittings in Zinc Plated Carbon Steel

FIXED MALE NPT or BSPT

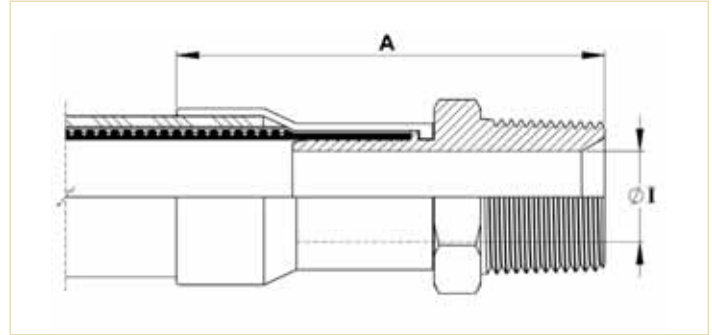

Nominal Hose Size		NPT or BSPT Thread Size	*Fitting Length A (Bioflex RC)		Fitting Inside Diameter I	
in	mm		in	mm	in	mm
1/2	13	1/2	3.30	84	0.38	9.53
3/4	20	3/4	3.74	95	0.63	15.88
1	25	1	4.13	105	0.80	20.24
1 1/4	32	1 1/4	4.90	124	1.00	25.40
1 1/2	40	1 1/2	5.19	132	1.25	31.75
2	50	2	5.78	142	1.75	44.45

FIXED FEMALE NPT

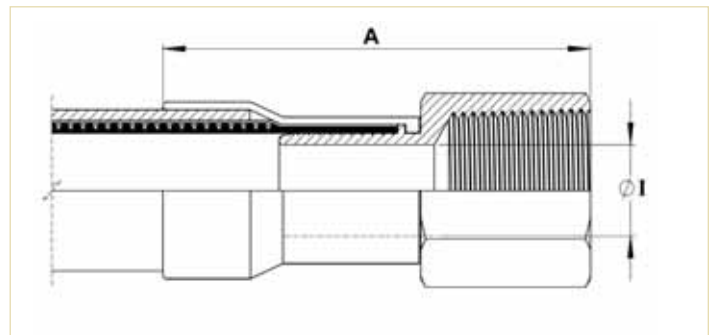

Nominal Hose Size		NPT ----Thread Size	*Fitting Length A (Bioflex RC)		Fitting Inside Diameter I	
in	mm		in	mm	in	mm
1/2	13	1/2	3.42	87	0.38	9.53
3/4	20	3/4	3.66	93	0.63	15.88
1	25	1	4.13	105	0.80	20.24
1 1/2	40	1 1/2	4.80	122	1.25	31.75
2	50	2	4.96	126	1.75	44.45

*Fitting lengths listed are for Bioflex RC, SI and FP Grades. Shorter lengths apply for other grades of Bioflex

Bioflex BSP 60° Cone Seat Female Unions and BSP Flat Seat Lug Nut Female

End Fitting Specification

- BSPP Threads to British Standard Pipe Parallel Thread design to BS21, 60° Cone Seat design, or Flat Seat.

Alternatives - Cone Seat Female Union Fittings can be supplied with a BSPP/BSPT Taper Male Adaptor if required.

End Fitting Materials

- Spigots in Grade 316L SS
- Nuts in Grade 316L SS
- Ferrules, most in Grae 304 SS, some sizes in Grade 316L SS

Alternatives

- Cone Seat Female Unions can be supplied in Zinc Plated Carbon Steel if required.
- Lug Nuts can be supplied in Gun Metal (Bronze) if required.

BSP 60° CONE SEAT FEMALE UNION FITTING

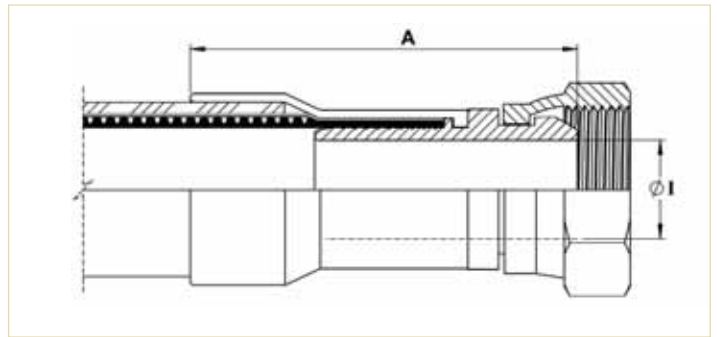

Nominal Hose Size		NPT or BSPT Thread Size	*Fitting Length A (Bioflex RC)		Fitting Inside Diameter I	
in	mm		in	mm	in	mm
1/2	13	1/2	3.27	83	0.37	9.35
3/4	20	3/4	3.62	92	0.63	15.88
1	25	1	3.86	98	0.80	20.24
1 1/2	40	1 1/2	4.65	118	1.25	31.75
2	50	2	4.80	122	1.75	44.45

BSP FLAT FACE LUG NUT FEMALE FITTING

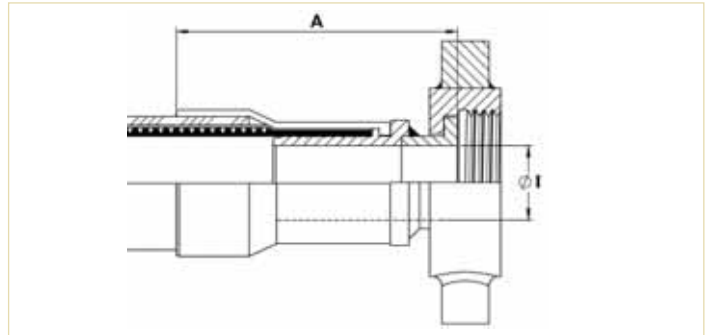

Nominal Hose Size		BSPP Thread Size	*Fitting Length A (Bioflex RC)		Fitting Bore Diameter I	
in	mm		in	mm	in	mm
1	25	1	3.70	94	0.80	20.24
1 1/2	40	1 1/2	3.66	93	1.25	31.75
2	50	2	3.70	94	1.75	44.45

*Fitting lengths listed are for Bioflex RC, SI and FP Grades. Shorter lengths apply for other grades of Bioflex

Bioflex 37° JIC Female Fittings and Male & Female NPT Unions

End Fitting Specification

- SAE J514 37° Flare JIC Female Fitting
- 37° JIC Male-to-NPT Male/Female Adaptors
- NPT Threads to ANSI B2.1

Temperature and Pressure Ratings

Same Maximum Working Pressure and Temperature as for the relevant size of Bioflex Hose, on page 6.

End Fitting Materials

- Spigots in Grade 316L SS
- Nuts in 316L SS
- Ferrules, most in Grade 304 SS, some sizes in Grade 316L SS

Note - Not usable with SAE 45° Flare fittings which have the same thread.

Alternatives - Can be supplied in other materials, such as zinc plated carbon steel, Hastelloy, Monel etc.

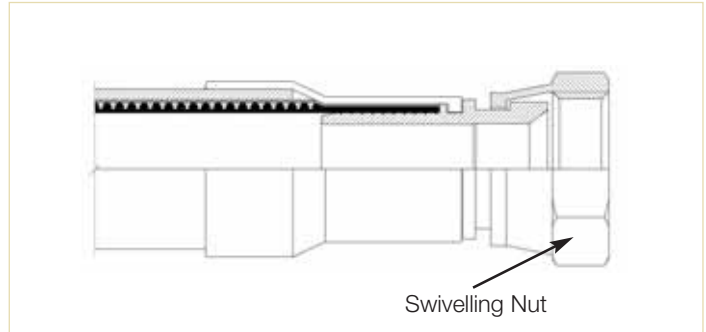

Nominal Hose Size		37° JIC Thread Size	*Fitting Length A (Bioflex RC)		Hex Size H		Fitting Inner Diameter I	
in	mm	in	in	mm	in	mm	in	mm
1/2	13	3/4 -16	2.76	70	0.88	22.2	0.38	9.5
3/4	20	1 1/16 -12	3.07	78	1.25	31.7	0.63	15.9
1	25	1 5/16 -12	3.23	82	1.50	38.1	0.80	20.2
1 1/2	40	1 7/8 -12	4.00	102	2.25	57.1	1.25	31.7
2	50	2 1/2 -12	4.33	110	2.88	73.0	1.75	44.4

JIC TO NPT MALE UNION (Including a JIC MALE-TO-NPT MALE ADAPTOR)

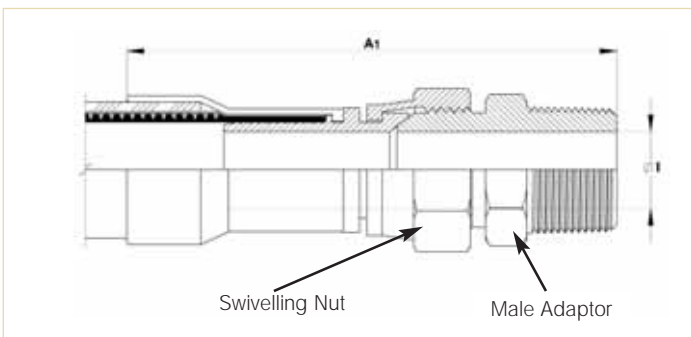

JIC TO NPT FEMALE UNION (Including a JIC MALE-TO-NPT FEMALE ADAPTOR)

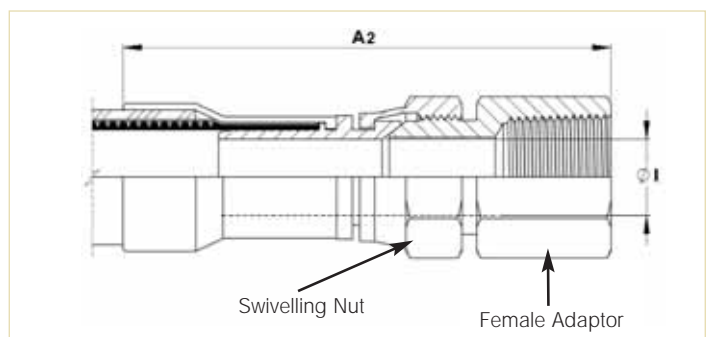

Nominal Hose Size		*Male Union Length A1 (Bioflex RC)		*Female Union Length A2 (Bioflex RC)		Fitting Inner Diameter I	
in	mm	in	mm	in	mm	in	mm
1/2	13	4.13	105	4.25	108	0.38	9.5
3/4	20	4.92	125	4.80	122	0.63	15.9
1	25	5.43	138	5.12	130	0.80	20.2

*Fitting lengths listed are for Bioflex RC, SI and FP Grades. Shorter lengths apply for other grades of Bioflex

Bioflex PTFE Dip Pipes, Straight or 90° Elbow

FIXED DIP PIPES

Description

Fixed Dip Pipes are fairly rigid, thick wall PTFE tubes, either straight or 90° elbowed, which are directly crimped to the end of Bioflex hoses. They are designed for insertion into drums, tanks and reaction vessels in order to suction drain (or inject) process fluids transferred through the hose.

Materials

- Standard dip pipes are in anti-static (AS) PTFE
- Ferrules, most in Grade 304 SS, some sizes in Grade 316L SS

How to order

Specify the size and material of the dip pipe, whether it is straight or 90° elbowed. Give the length of the straight leg of the dip pipe and the length of the rest of the hose assembly separately.

Maximum Working Pressures

Dip Pipes are normally only tested to 4 Bar Pressure, and are not suitable for use at pressures higher than 3 Bar. They are usable at negative pressure up to full vacuum.

If higher pressure ratings are required, consult Aflex Hose.

Lengths

Dip Pipes are supplied as standard in 1 metre straight lengths, but can be supplied in any length to individual requirements.

FIXED DIP PIPE (90° ELBOW)



Nominal Hose Bore Size		Approximate Dip Pipe Dimensions			
		Outside Diameter D		Inside Diameter I	
in	mm	in	mm	in	mm
3/4	20	0.87	22	0.51	13
1	25	1.14	29	0.83	21
1 1/2	40	1.54	39	1.00	27
2	50	2.17	55	1.58	40

FIXED DIP PIPE (STRAIGHT)

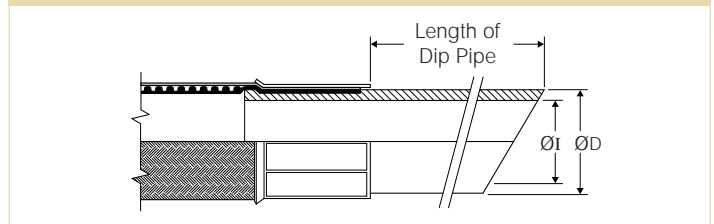

DETACHABLE DIP PIPES

Description

As Fixed Dip Pipes above, but connected to the hose through an end fitting, not by crimping direct to the hose.

Design

A straight, or 90° elbowed anti-static PTFE Dip Pipe, fitted with a Flange or Cam & Groove Male PTFE Lined & Flared end fitting.

The most usual end fitting is a Cam Male (as shown), so the dip pipe can then be connected to a hose with a Cam Female end fitting.

Specifications

As above for Fixed Dip Pipes.

DETACHABLE DIP PIPE

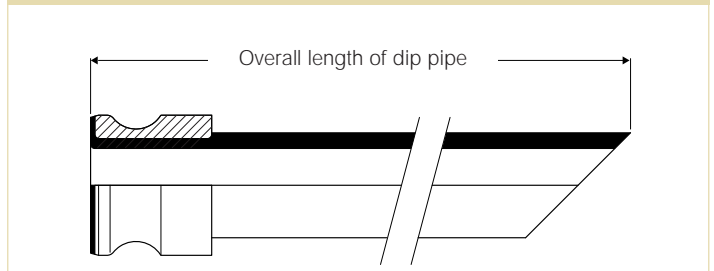

Bioflex 90° Elbow Fittings, PTFE Lined and Non-Lined

PTFE LINED 90° ELBOW FITTINGS

Scope - All of the PTFE lined end fittings described on previous pages can be fitted as 90° elbow PTFE lined fittings to the design shown, to the sizes listed.

- All grades of hose can be used, except PB and KYB.

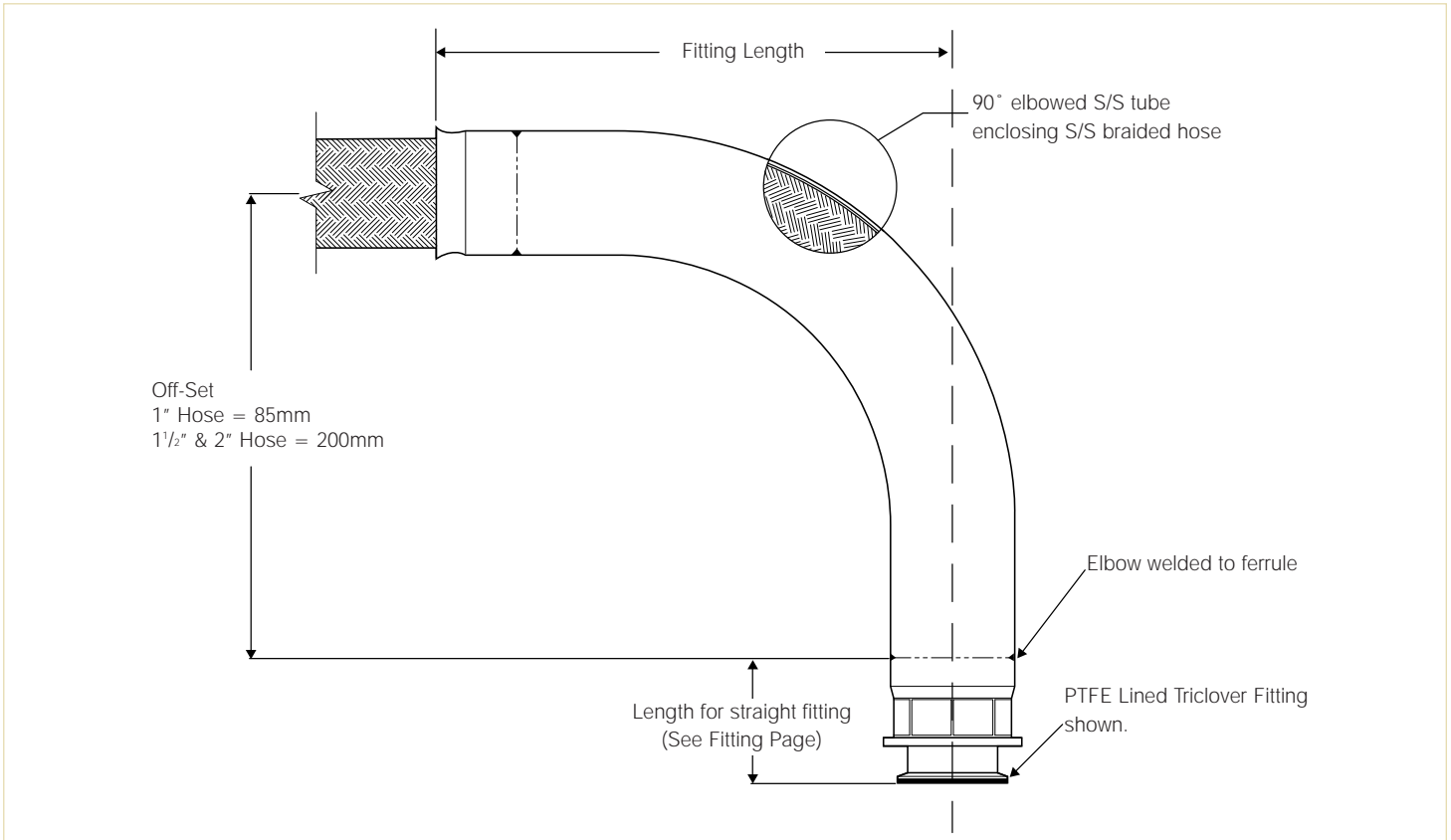

Hose Bore Sizes	Off-Set	Fitting Length
	mm	mm
7/8" or 1"	85	143
1 3/8" or 1 1/2"	200	237
1 7/8" or 2"	200	314

NON-LINED 90° ELBOW END FITTINGS

A 90° elbow attached to the hose can be supplied non-PTFE lined, as shown, for any size or grade of hose or type of fittings, to special order.

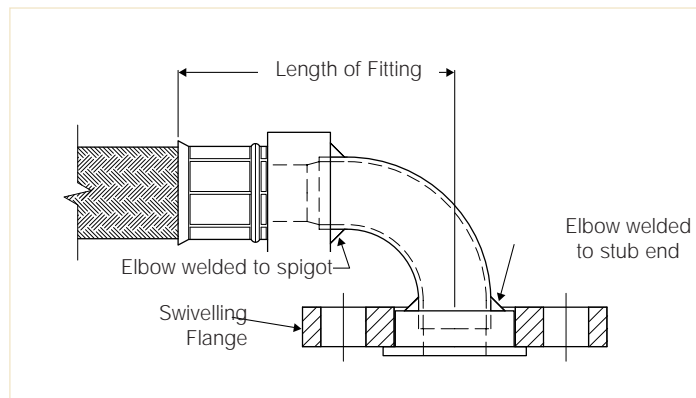

Bioflex Steam Heated Hose Assemblies. (CH Grade)



Purpose

For use in applications where the temperature of the process fluid must be maintained as it passes through the hose. This is usually required to prevent solidification or an increase in fluid viscosity. Steam heating is preferred to electrical heating in some applications for reasons of availability or safety, but is less controllable.

Description

The heating element comprises a small diameter PTFE heating hose, 1/4" or 3/8" bore size, with a single SS wire braid. This is spirally wrapped around the hose, with inlet and outlet ports attached, either both at one end or at opposite ends of the hose assembly. In the case of hose assemblies longer than 3 metres, it is usual to have several heating hoses with inlet ports at opposite ends and along the hose. This reduces the effects of temperature loss over the length of the Hose Assembly. The thermal insulation is usually closed-cell silicone foam rubber. The outer cover is a SS wire braid with a rubber cover if necessary.

Design

Each hose is custom designed and built to suit the requirements of the particular application. The following information is therefore required:

- Fluid in Hose Assembly
- Maintained Temperature of Fluid in Hose
- Temperature of Steam or Fluid in the Heating Hose
- Min/Max Ambient Temperature
- Pressure/Vacuum Applied to Fluid
- External Conditions of Abrasion etc

Specifications

As for Bioflex GP, SS on pages 9 and 10, except that the minimum bend radius is tripled, and the outside diameter and weight are significantly increased in line with the particular design.

Limitations

1" PTFE lined PN10 flange spigots on heated hoses can only have a maximum flare diameter of 50mm, not 63mm.

If the hose is "hanging", straight or at 90°, under its own weight, special construction is required, so advise Aflex Hose accordingly.

Minimum CH Hose Assembly Length 750mm.

CH Hose Assembly

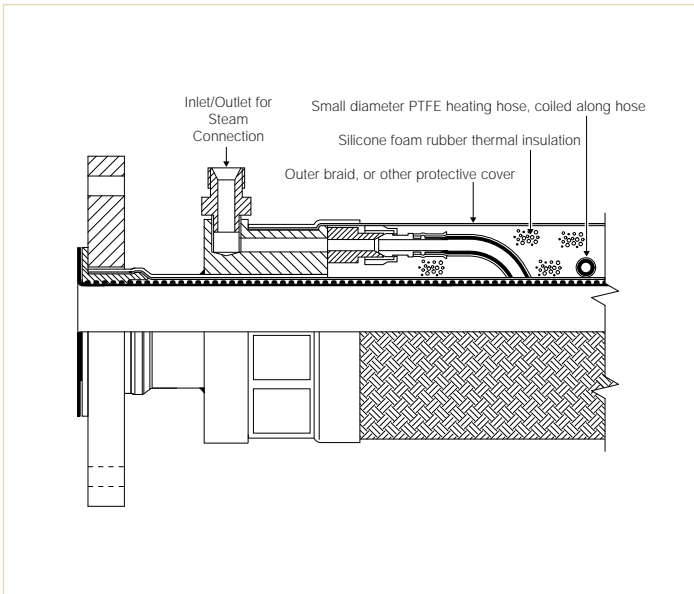

Bioflex Electrically Trace Heated Hose Assemblies. (ETH Grade)

Purpose

For use in applications where the temperature of the process fluid must be regulated as it passes through the hose. In some applications, an additional 'melt out' facility may also be required.

Description

The heating element comprises either a resistance or self-regulating element spirally wrapped around the hose assembly. Self regulating elements may require a sensor and controller if a specific maintain temperature is required. Please consult Aflex Hose for clarification. Resistance element heated hoses usually also require a temperature sensor to be built in to the construction and must be used in conjunction with a temperature controller. The power leads and (if applicable) temperature sensor leads emerge from the hose assembly at one end, through glands and conduits. The thermal insulation is foam rubber, silicone foam rubber for temperatures above 80°C (176°F). The outer cover may be a polypropylene yarn or SS wire braid with a rubber cover if necessary.

Design

Each hose is custom designed and built. Application details must be supplied by filling in an "ETH Hose Questionnaire", available from Aflex Hose. Generally, for Hazardous Areas, particularly "ZONE 1", the Self Regulating type of heating element is employed, with or without a temperature sensor and control, and flameproof glands and conduit are also required. The watts per metre of the heating element, the pitch of the spiral on the hose, and the thickness of the thermal insulation are all calculated in accordance with established formulae to give the required maintained temperature.

Specifications

As for Bioflex GP, SS on pages 9 and 10, except that the Minimum Bend Radius is tripled and the outside diameter and weight are significantly increased in line with the particular design. Maximum ETH Hose Assembly Lengths are as Bioflex GP, SS.

Limitations

1" PTFE lined PN10 flange spigots on heated hoses can only have a maximum flare diameter of 50mm, not 63mm.

If the hose is "hanging", straight or at 90°, under its own weight, special construction is required, so advise Aflex Hose accordingly.

Minimum ETH Hose Assembly Length, when collars are used 750mm.

ETH Hose Assembly

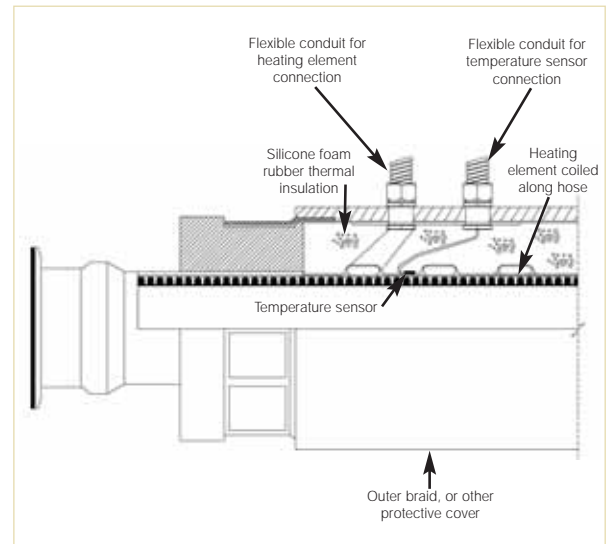

Bioflex Standard and Puretag Labelling and Colour Coding Systems

Standard Labelling

All Bioflex hose assemblies are labelled with the following information:

- Manufacturer's Name (Aflex Hose USA, LLC)
- Hose Size and Grade
- Max. Working Pressure
- Unique Serial Number
- Month & Year of Manufacture
- Aflex Hose Telephone Number
- CE Mark (if applicable)

This information is normally vibro-etched on to a loose stainless steel Ring mounted on the hose.

In some cases, at the discretion of Aflex Hose, the information may be etched on to a thin stainless steel plate which is clamped to the hose, or on to the end fitting ferrule at one end. This may be necessary for example, if the customer requires additional information which may not fit on to a Ring.

Customers may specify which labelling system they require, and may request additional information on the label.



Puretag Labelling and Colour Coding

This system is only applicable to the EPDM (RC or FP) or Silicone (SI) rubber covered grades of Corroflon.

A label and/or Colour Code is encapsulated on to the braid by a transparent rubber cover which is integrally vulcanised and fully bonded to the rubber cover on the hose.

Another alternative is an RFID programmable tag, encapsulated in the Rubber (Aflex Hose "Flowtag" system) - consult Aflex Hose for details.

Further information is available on the Puretag product information document on the website.



Colour Coding

This system is applicable to all grades of Bioflex hose.

A coloured PTFE spiral strip is wound on to the hose.

It can be left loose, or it can be encapsulated under a transparent, heat-shrunk polyolefin sleeve.



Correct Hose Configuration & Length Calculations - for Bend Radius

Hose Configuration Requirements

Hose Assemblies are usually connected at both ends in service. They may then either remain in a fixed, or static configuration or in a flexing, or dynamic configuration.

Whether static or dynamic, the First Rule concerning the configuration of the hose is that the bend radius of the hose must never be less than the Minimum Bend Radius (MBR) for the hose as listed in the relevant hose brochure.

The most common situation when this is likely to occur is when the hose is flexed at the end fitting, with stress being applied to the hose at an angle to the axis of the end fitting. Typically, this happens either because the length of the hose is too short, or because the weight of the hose plus contents creates a stress at an angle to the end fitting.

The Second Rule, therefore, if possible, is to design the configuration to ensure that any flexing in the hose takes place away from the end fittings.

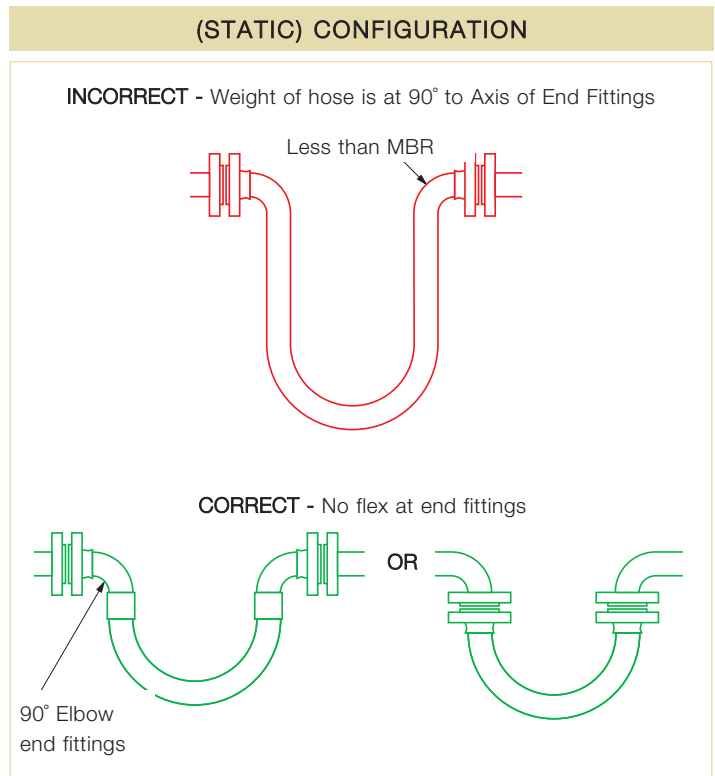
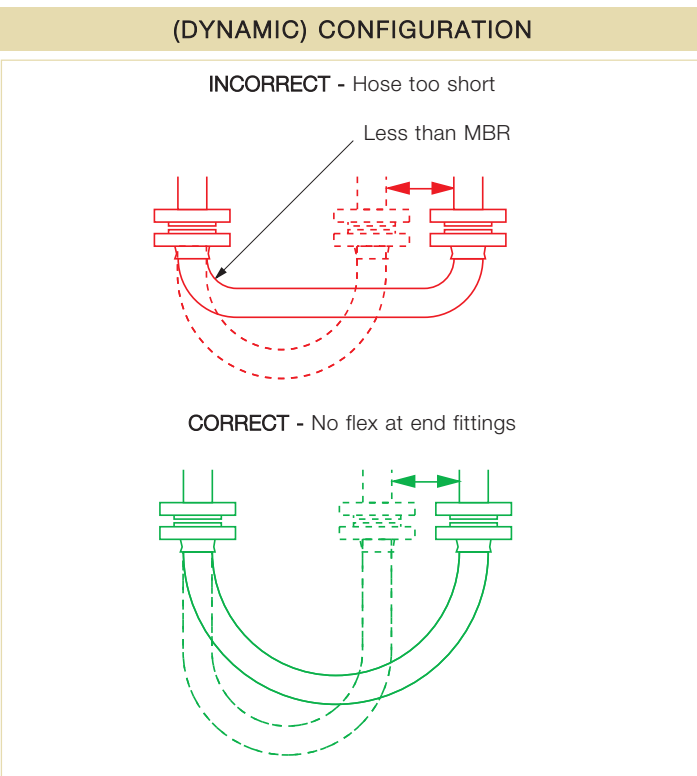

Correct Hose Configuration & Length Calculations - for Abrasion & Torque

The Third Rule is that the hose configuration should always be designed, and supported where necessary, to avoid any possibility of external abrasion.

In some cases, the length, configuration and angle of the hose can be designed to avoid abrasion. In others, static or moving support frames or support wheels are required.

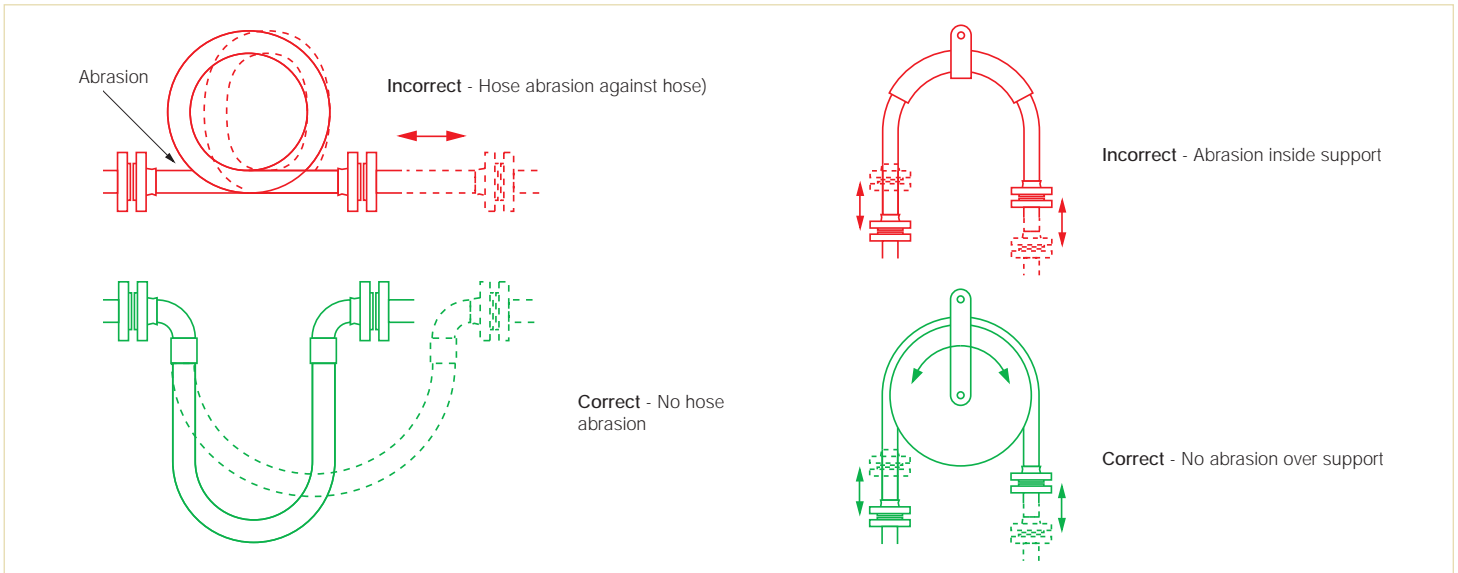

The Fourth Rule is that the hose must not be subjected to torque, either during connection, or as a result of the flexing cycle.

Torque (twist) in the hose can be applied during connection if the hose is accidentally twisted, or if the second end being connected is a screwed connection, and the hose is subjected to torque during final tightening.

In a flexing application, if any flexing cycle of the hose occurs in 3 dimensions instead of 2, then torque will also occur:

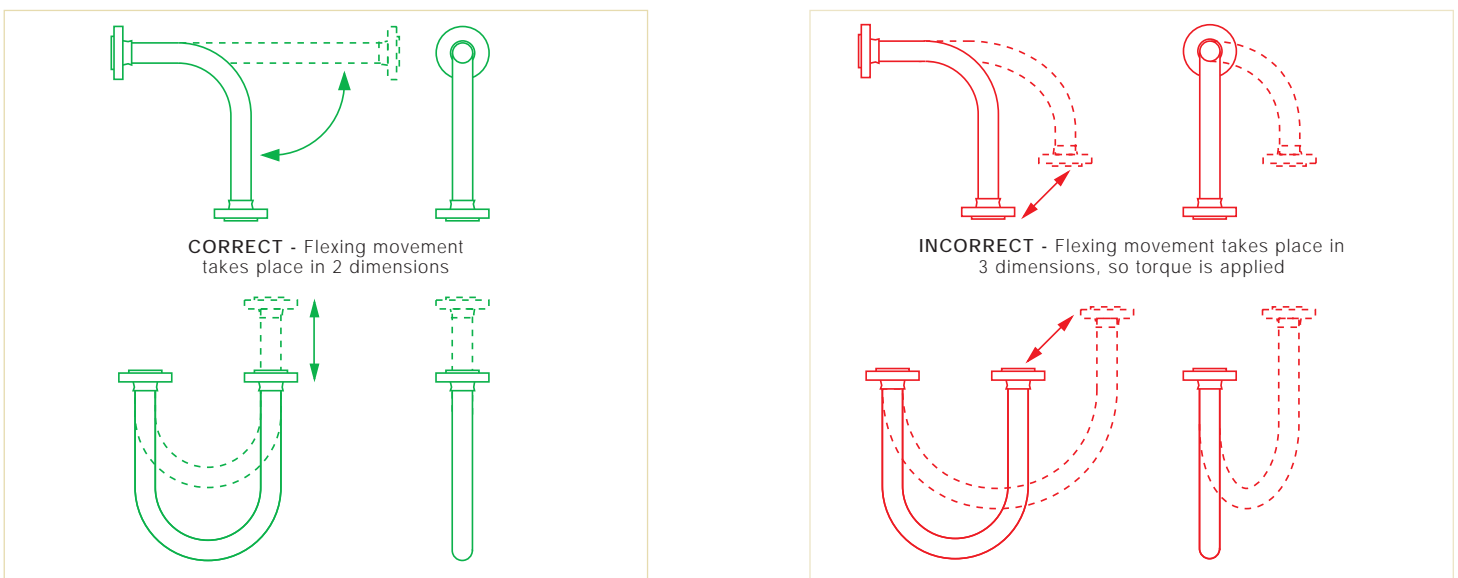

Both Corroflon and Bioflex hose have good resistance to a small level of torque, much better resistance than rubber or SS hose types, but it is still the best practice to take whatever steps are necessary to eliminate torque. If in doubt, consult Aflex Hose.

Hose Configurations & Length Calculations

- for Length Calculation

Calculating the Hose Length

The formula for calculating the bent section of the hose length around a radius is derived from the basic formula that the circumference of a circle = $2\pi R$, where R = the radius of the circle, and π = a constant, = 3.142.

So, if the hose goes around a 90° bend, which is 1/4 of a full circumference, and the radius of the bend is R , then the length of the hose around the bend is = $1/4 \times 2\pi R$. Or half way round, in a U-shape, = $1/2 \times 2\pi R$.

Note :

In calculating the length of a hose assembly, the (non-flexible) length of the end fittings must be added in, also the length of any straight sections of hose, as in the following example:

Example :

To calculate the length for a 2" bore size hose with flange end fittings, to be fitted in a 90° configuration with one leg 400mm long, the other 600mm long.

Length of Bent Section (yellow) = $1/4 \times 2\pi R$ (334)
 = $1/4 \times 2 \times 3.142 \times 334 = 525\text{mm}$

Length of top, Straight Section, including the top end fitting length
 = $600 - 334 = 266\text{mm}$

Length of bottom end fitting = 66mm

Total length of Hose Assembly = $525 + 266 + 66 = 857\text{mm}$

Things to consider

- (a) A hose will normally take the longest radius available to it to go around a corner, not the MBR! Also - always remember to include the **non-flexible** end fitting lengths.
- (b) In dynamic applications, remember to always calculate the lengths for the most extended configuration during the flexing cycle, not the least extended.
- (c) If the configuration is simply too complex for calculation, then obtain a length of flexible tubing of some kind, mark on paper, or a wall, or floor, or both where the connection points will be relative to each other, scaled down if necessary, then manually run the flexible tubing between them with full radii round bends. Measure the extended length, then scale up if necessary to determine the approximate length of the hose.

If in doubt, consult Aflex Hose.

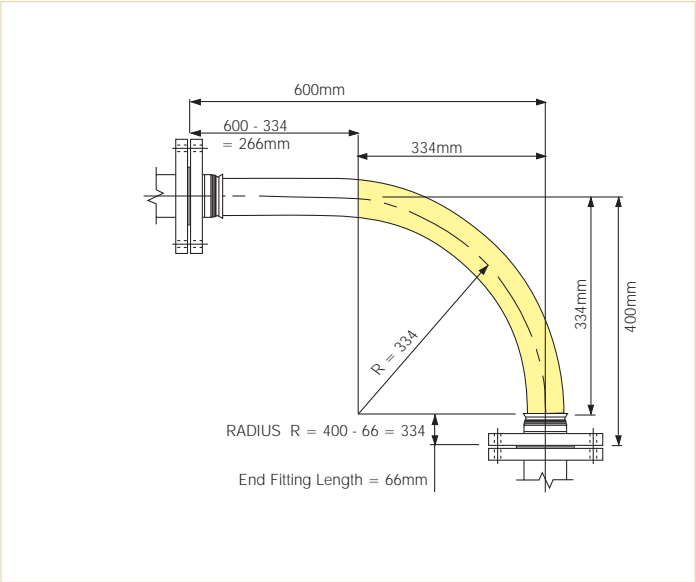
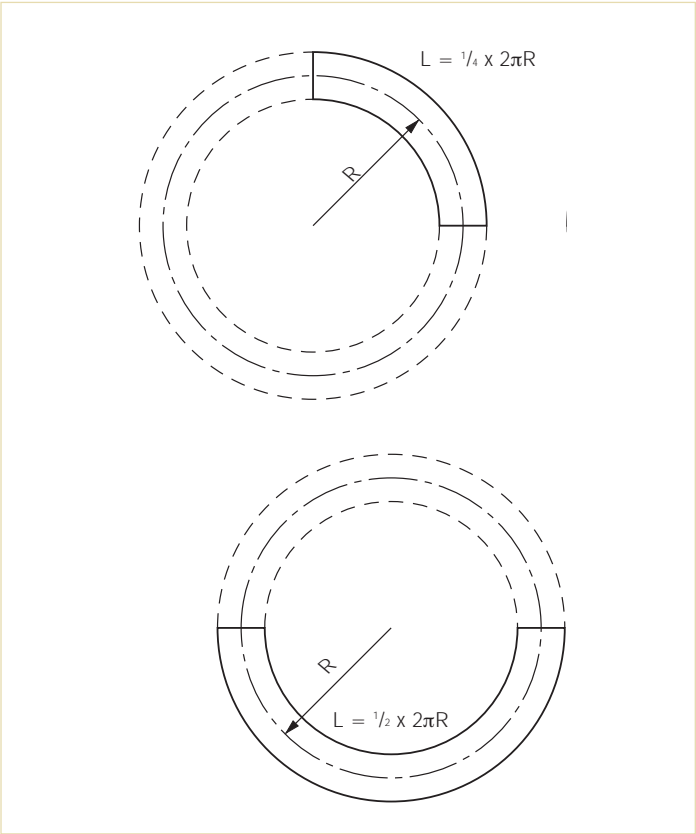

Conditions of Sale

General

Aflex PTFE hose products have not been designed or tested to be suitable for use in any **Aerospace, Medical Implantation or Radioactive applications** and such use is therefore strictly prohibited unless written approval from Aflex Hose USA, LLC has been given.

Aflex Hose USA, LLC will not accept liability for any failures of the Aflex Hose Products which are caused by customers failing to perform their Responsibilities as specified in these Conditions of Sale.

It is the customer's strict Responsibility to review all of the usage limitations given for the hose which he intends to use in an application, to ensure that the application conditions are in compliance with those usage limitations. The usage limitations are specified both on this page, in the **Full Brochures** for the relevant products on the Aflex Hose website. Customers must always consult the latest, up to date information, which is only available and downloadable from the Aflex website.

It must be accepted, however, that the usage limitations specified elsewhere in the Hose Product Information and on this page are intended as a guide only, since every possible factor in every type of application cannot possibly be covered. It is therefore the Customer's Responsibility to ensure the design suitability and safety of the products in their intended applications, giving particular consideration to the chemical and electrostatic compatibility of the fluids or gases passing through, the possibility of diffusion of fluid or gases through the PTFE hose lining, the possibility of external corrosive conditions, the types and likelihood of excessive mechanical abuse, such as abrasion (internal or external), crushing, excessive flexing or vibrations etc, and any excessive temperature and/or pressure "pulsing" conditions, all of which may cause premature hose failure. It is also the Customer's Responsibility to consider, and take account of the degree of risk involved in any hose failure, including the provision of adequate protection in the event of any risk to employees or the general public. In applications where any type of hose failure would lead to financial losses if the hose is not replaced immediately, it is the Customer's Responsibility to order and hold in stock spare hose(s) accordingly. It is also the Customer's Responsibility to advise Aflex Hose in writing if there are any special requirements for the hose, including cleaning, or drying, or extra testing requirements which are in addition to normal industrial standards.

If the Customer has any doubts concerning these or any other usage limitation or safety parameters, it is the Customer's Responsibility to consult Aflex Hose USA, LLC, to request a written response to any queries.

It is the Responsibility of the Customer to ensure that if the product is sold on, or passed on, however many times, that all the necessary information including this page and the Aflex Hose website address are also passed on to the final user, together with a specific requirement that the final user must review the usage limitations in terms of his own application.

Hose Service Life

It is not possible to guarantee a minimum service life for any of the Aflex Hose products which can be applicable for every type of application.

(For example, PTFE lined hose has been used in one application where it was cycled with hot steam, then cold water, also flexed every 17 seconds 24 hours per day, and the customer was very satisfied with a service life of 3 weeks before failure. In other light duty applications carrying pharmaceutical products, however, many Corroflon hoses are still performing satisfactorily after 20 years in service).

Service life predictions or guarantees can only be given in cases where all the relevant information concerning the application is given in writing to Aflex Hose, and Aflex Hose subsequently replies in writing prior to the order being placed.

If such a written undertaking is not sought and given, then Aflex Hose cannot be held liable for any hose product failure which the customer considers to be premature, excepting failures which are due to faulty materials or manufacturing defects.

24 Month Warranty

Aflex Hose USA, LLC warrants its products to be free from faulty materials or manufacturing defects from the date of the initial sale, for 24 months.

N.B. All ETH hoses are only warranted for 12 months.

Product Failure

In the event of a product failure, Aflex Hose requests that the product should not be cut up or tampered with, but should be de-contaminated and returned to Aflex Hose, plus a decontamination certificate, for examination and analysis of the fault. The customer should also provide full details in writing of the application conditions under which the hose failed, including Pressure, Vacuum, Temperature, Flexing and any cycling of any of these, also the fluid and gases passing through the hose, and the total time that the hose has been in service. The customer may send his own witness to the examination if required. Aflex Hose will provide a full Non Conformance Report for the customer.

If faulty materials or a manufacturing defect in the hose was responsible for the failure to perform then, the maximum liability to be accepted by Aflex Hose would include the invoice value of the failed hose itself, or the invoice value of the whole customer order if appropriate, also any reasonable costs for removal and replacement of the hose, and costs for packing and despatching the failed hose back to Aflex Hose. Aflex Hose USA, LLC will not accept liability for any other consequential or financial losses, including, but not limited to loss of profits, loss of products or downtime costs.

Untested Hose for Self Assembly by Customers

Aflex Hose sometimes supplies "loose" hose, without end fittings attached to Self Assembly Customers, who will then cut the hose to length and attach end fittings to make up Hose Assemblies.

Self Assembly Customers must then accept the responsibility to carry out pressure testing of 100% of such assemblies to 1^{1/2} times the Maximum Working Pressure (MWP) if the hose as listed in the Full Product Brochure before supply for end use, to validate both the hose and the end fitting attachment.

When pressure testing hoses with a plastic or rubber outer cover, the cover will mask any signs of leakage for a time. It is therefore recommended that after the Hydrostatic Pressure Test, the hose should be tested at the MWP with air under water for a minimum test period of 5 minutes.

Unless the customer requests, and Aflex Hose confirm that their loose hose is pressure tested before supply, such testing is not normally applied by Aflex Hose, because this testing requirement is satisfied by the Self Assembly Customer during his own testing of the finished Hose Assembly.

The Self Assembly Customer must also accept responsibility for determining and approving the Design Suitability of the hose assemblies for their intended use before supply.

This includes determining and requesting or applying any special tests which may be identified as necessary to ensure suitability for the intended use.

Aflex Hose will only accept liability for its hose products which are assembled by Aflex Approved Self-Assembly Companies if all the hose and fitting components were supplied by Aflex Hose or approved for use by Aflex Hose, and they were assembled and tested in accordance with Aflex Hose's current Manufacturing and Testing Instructions, available to approved Self Assemblers in an I-Bay on the Aflex Hose website.

Untested Hose Assemblies

Aflex Hose is sometimes requested by customers to attach non-standard end fittings to hose assemblies which they supply, and in some cases it is not possible to connect these fittings to the pressure test system. In such cases a Concession not to test is obtained from the Customer, and a label is attached to the hose assembly, warning that it requires pressure testing before use.

Force Majeure

Aflex Hose USA, LLC shall not be liable for any delay or default in performing in accordance with any Customers' order if the delay or default is caused by conditions beyond its control, including, but not limited to wars, insurrections, strikes, natural disasters or performance failures by Carriers, sub-contractors or other third parties outside the control of Aflex Hose USA, LLC.

Legal System

This agreement and any sales thereunder shall be governed by the laws of the Commonwealth of Pennsylvania, without regard to conflicts of laws rules.



The World's Leading Manufacturer of PTFE Flexible Hose.

6111 Keller's Church Road, Unit B,
Pipersville, Pennsylvania, PA 18947
T: 215 766 1455 F: 215 766 1688
W: www.aflex-hose.com

