

SPS PUMPS

Sanitary and industrial pumps for up to 15 bar pressure and in-line cleaning



MasoSine SPS Pumps Sanitary and industrial pumps

Experts describe the MasoSine SPS pump as “a stroke of genius in pump technology”. The sine-wave principle practically reinvents the positive displacement pump and creates a powerful, extraordinarily effective unit with delivery of up to 90,000 litre/hour. This model is a sanitary and industry pump for up to 15 bar pressure and in-line cleaning.

The sine-wave-shaped rotor creates four moving chambers which gently convey the duty fluid from the inlet port to the higher-pressure discharge port. The scraper gate prevents any fluid passing back from the discharge side to the lower-pressure suction side of the pump.



The sine functional principle

Like peristaltic pumping, the MasoSine pumping principle requires no valves. The four chambers are sealed. The system is ideal for fluids carrying soft solids such as fruit, and viscous media such as sauces and silicones.

The MasoSine SPS pump embodies a technological revolution which practically reinvents the positive displacement pump.

Scraper gate creating a seal between suction and pressure chambers

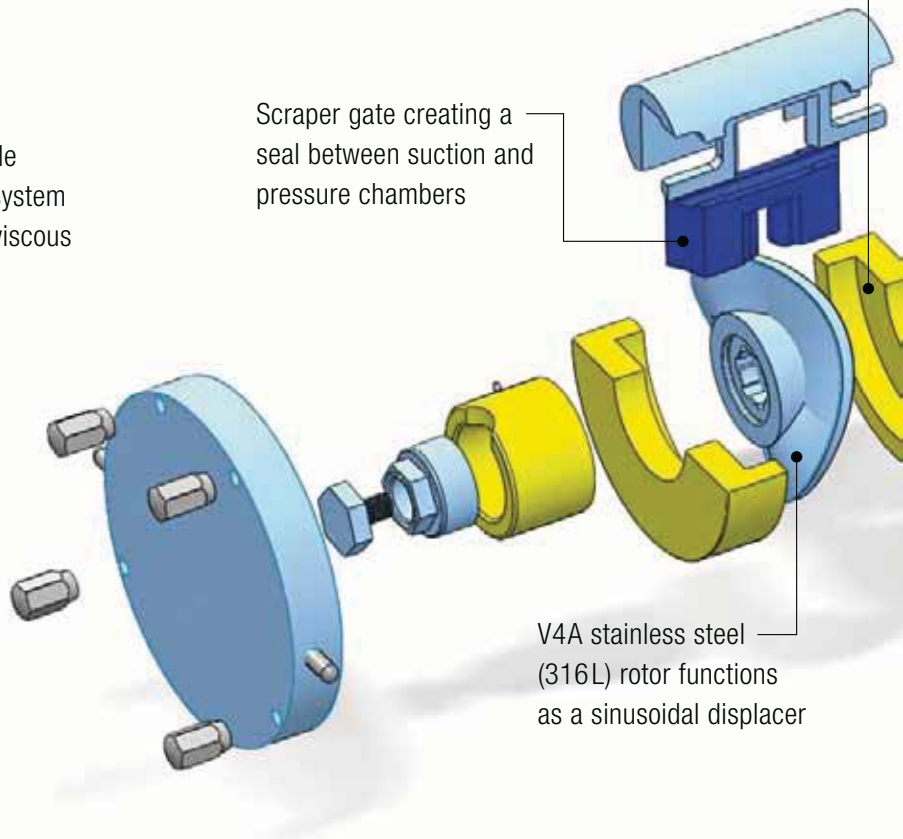

V4A stainless steel (316L) rotor functions as a sinusoidal displacer

MasoSine SPS Pumps Features and benefits



High flow rate

Flow rates up to 90,000 litre/hour, even with viscous fluids.

Enormous flexibility

Masosine SPS pumps are matched to the customer's requirements and the duty fluid. We vary the materials, the drive, the baseplate and the casing as needed – we even create bespoke pumps within the SPS range.

Gentle delivery

The gentle pumping action means no damage to shear-sensitive fluids.

Suction capability

The SPS pump can achieve 0.85 bar suction.

Low pulsation

The low-pulsation performance of the SPS pump prevents vibration in pipelines and ensures rapid, smooth discharge. Flow meter readings are more accurate and heat exchanger performance is more efficient.

Space saving

The SPS is a compact, space-saving design, ideal for space-critical installations.

No foaming

The low-shear, gentle pumping action causes no aeration or foaming during product transfer.

High viscosity no problem

SPS pumps handle high and low viscosity fluids with the same pump configuration.

Quick and easy maintenance

Stripping the pump for inspection or to change a part takes less than 10 minutes and needs no special skills or training: a short briefing is sufficient. The SPS minimises downtime.

24 hour service

Essential spare parts can be delivered on the day the order is received. Standard pumps can be despatched within 24 hours.

10 year warranty

Our 10 year pump-body guarantee proves our confidence in the MasoSine SPS pump.

— Liners made of the right material for your duty fluid

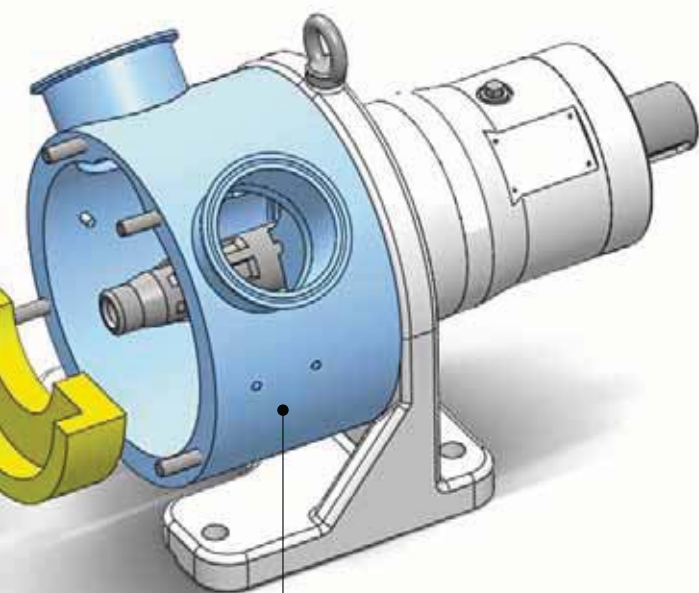

— Pump housing made of V4A stainless steel (316L)

MasoSine SPS Pumps Performance tables

These curves are theoretical. Actual performance may be affected by pressure and viscosity.

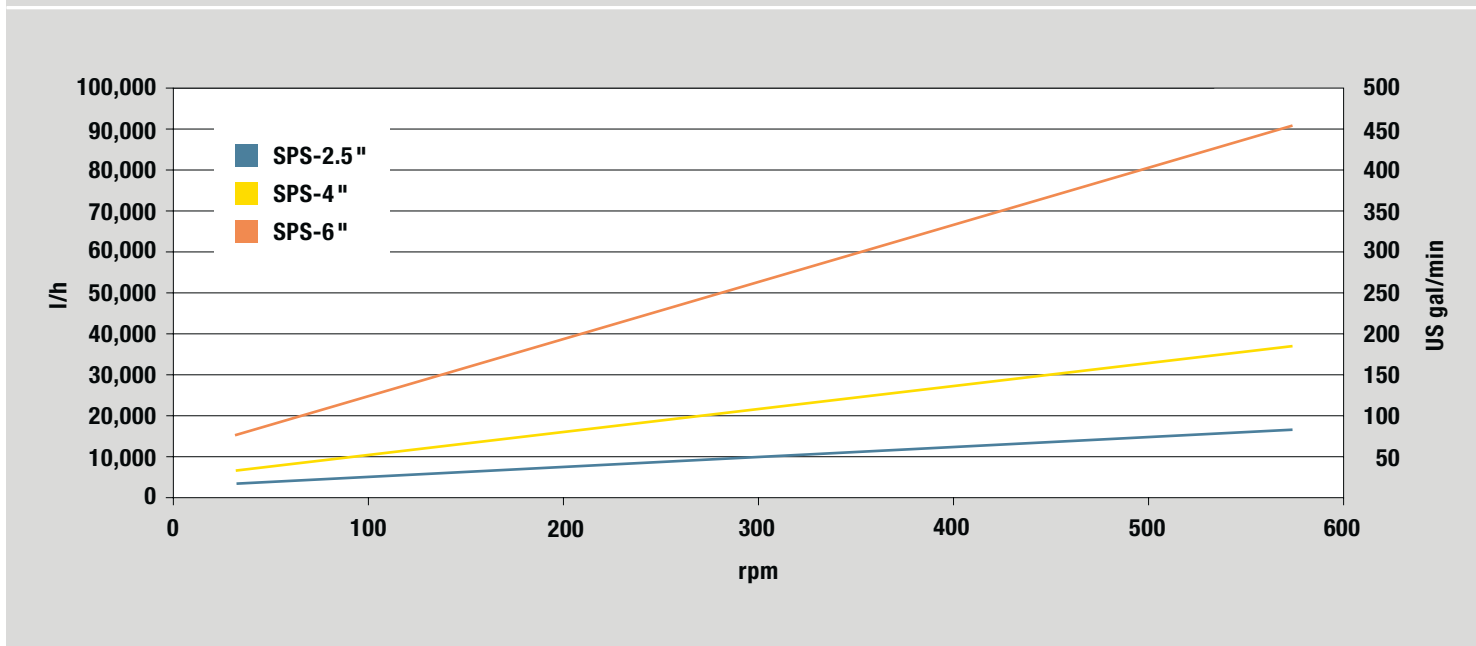
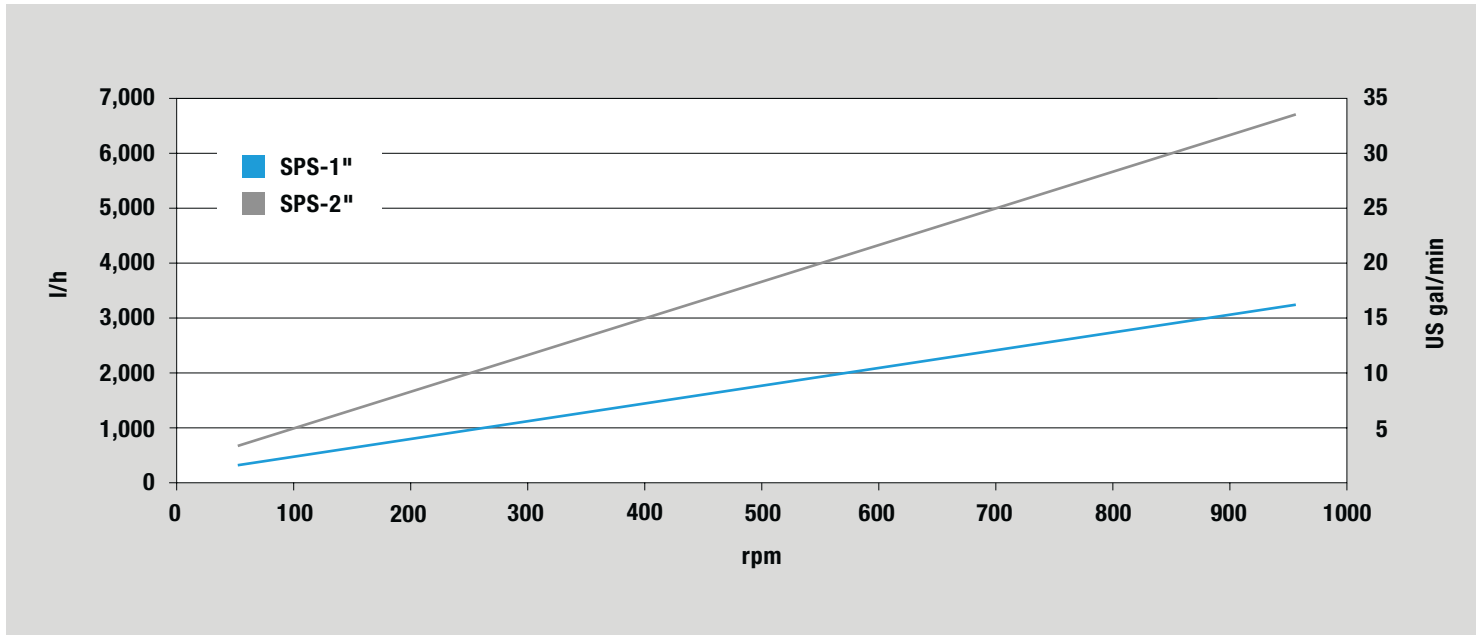

| Technical Data | | | | | |
|----------------|--|--------------------------------------|----------------------|-------------------------------|-----------------------------|
| model | flow per revolution cm ³ - (gallons) | maximum particle size mm (inches) | maximum speed rpm | shaft diameter mm (inches) | shaft height mm (inches) |
| SPS-1" | 53 cm ³ (0.02 gal) | 10 mm (0.39 in) | 1,000 rpm | 18 mm (0.71 in) | 72 mm (2.83 in) |
| SPS-2" | 110 cm ³ (0.03 gal) | 20 mm (0.79 in) | 1,000 rpm | 28 mm (1.10 in) | 95 mm (3.74 in) |
| SPS-2.5" | 450 cm ³ (0.12 gal) | 30 mm (1.18 in) | 600 rpm | 45 mm (1.77 in) | 150 mm (5.91 in) |
| SPS-4" | 1050 cm ³ (0.28 gal) | 48 mm (1.89 in) | 600 rpm | 50 mm (1.97 in) | 195 mm (7.68 in) |
| SPS-6" | 2500 cm ³ (0.67 gal) | 60 mm (2.36 in) | 600 rpm | 65 mm (2.56 in) | 235 mm (9.25 in) |

MasoSine SPS Pumps Applications



Food products

The SPS pump is well-established in the food industry for transferring fluids containing soft solids. Typical applications include ready meals, soups, sauces, frozen foods, salads and sausage meat. Loading filling machines is a MasoSine speciality.



Beverages

The high suction capacity of the SPS pump, 0.85 bar, is valuable to the beverage industry. Orange juice concentrates with temperatures down to -10°C and other fruit juices are transferred without damaging the product.



Dairy products

MasoSine SPS pumps are ideal for transferring sensitive cheese curd, yoghurt, cream cheese, cottage cheese and cream. They are also perfect for adding fruit preparations and handling butter.



Cosmetics and pharmaceuticals

SPS pumps have been successfully used in the cosmetics industry for many years for gentle transfer of shampoos, creams, pastes and lotions. The highest hygienic standards, no pulsation, gentle conveyance and CIP also make the SPS series pump very successful in biopharmaceutical applications.



Fine chemicals

SPS pumps stand out from the competition for handling shear-sensitive suspensions, solutions, washing-up liquid and detergents, as well as very viscous media such as silicones.



Confectionery

In the confectionery industry, SPS pumps transfer chocolate glazes and fillings, glucose, fats and many other products. A pump-housing heater is available for this application area.

The Watson-Marlow Pumps Group has five world-class factories supported by direct sales operations in 19 countries and distributors in more than 50 countries. For contact details visit our website:

www.wmpg.com

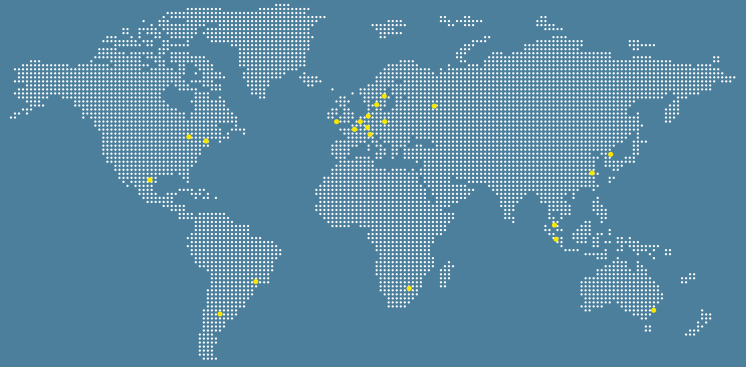

MasoSine Watson-Marlow Bredel Alitea Flexicon



Watson-Marlow online

Our engineers around the world can help you choose the perfect pump and tubing for your needs.

More information?

Our brochures are on our website:

www.wmpg.com



Watson-Marlow MasoSine

Postfach 100

74360 Ilsfeld · Germany

Tel. +49 (0) 70 62 / 95 60-0

Fax +49 (0) 70 62 / 6 45 93

E-Mail: info@masosine.de

www.masosine.com

Watson-Marlow... Innovation in Full Flow