

Distributed by:

Tri-Canada

Tel: 905.677.9000 • Toll Free: 1.800.486.7863
www.tricanada.com

GEMÜ®

**Diaphragm Valve,
Metal**

Construction

The GEMÜ 687 pneumatically operated 2/2-way diaphragm valve has a low maintenance actuator. Normally Closed, Normally Open and Double Acting control functions are available.

Features

- Suitable for inert and corrosive* liquid and gaseous media
- Chemical resistance of actuator
- Stainless steel body with CIP/SIP cleaning and sterilising capabilities
- Insensitive to particulate media
- Valve body and diaphragm available in various materials and designs
- Various connections available
- Surface finishes down to 0.25 µm, electropolished
- Versions according to ATEX on request
- Optical position indicator is standard for control function 1

Advantages

- The modular actuator system permits a variety of options to be used such as tank bottom valves, T valves, sampling valves, multi-port valves and tandem welded configurations
- Optional flow direction
- Installation for an optimized draining is possible
- Optional accessories:
 - Stroke limiter
 - Optical position indicator control function 2 + 3
 - Manual override (GEMÜ 1002, GEMÜ 1004)
 - Pilot valve with manual override (GEMÜ 0322 - 0326)
 - Electrical position indicators

*see information on working medium on page 2



Sectional drawing

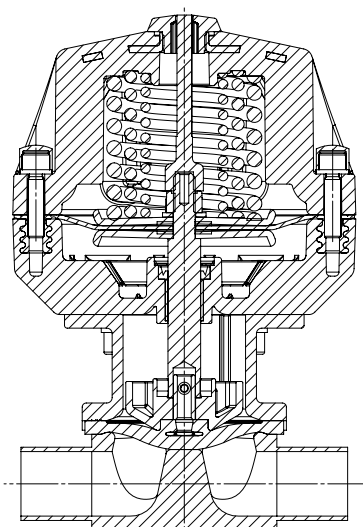

GEMÜ® 687

Technical data

Working medium

Corrosive, inert, gaseous and liquid media which have no negative impact on the physical and chemical properties of the body and diaphragm material.

Temperatures

Medium temperature

FPM (code 4)	-10 ... 90 °C
EPDM (code 13)	-10 ... 100 °C
EPDM (code 14)	-10 ... 90 °C
EPDM (code 17)	-10 ... 100 °C
PTFE (code 52)	-10 ... 100 °C
PTFE (code 5E)	-10 ... 100 °C

Sterilisation temperature ⁽¹⁾

FPM (code 4)	not applicable
EPDM (code 13)	max. 150 °C ⁽²⁾ , max. 60 min per cycle
EPDM (code 14)	not applicable
EPDM (code 17)	max. 150 °C ⁽²⁾ , max. 180 min per cycle
PTFE (code 52)	max. 150 °C ⁽²⁾ , no time limit per cycle
PTFE (code 5E)	max. 150 °C ⁽²⁾ , no time limit per cycle

¹ The sterilisation temperature is valid for steam (saturated steam) or superheated water.

² If the sterilisation temperatures listed above are applied to the EPDM diaphragms for longer periods of time, the service life of the diaphragms will be reduced. In these cases, maintenance cycles must be adapted accordingly. This also applies to PTFE diaphragms exposed to high temperature fluctuations.

PTFE diaphragms can also be used as moisture barriers; however, this will reduce their service life.

The maintenance cycles must be adapted accordingly.

GEMÜ 555 and 505 globe valves are particularly suitable for use in the area of steam generation and distribution.

The following valve arrangement for interfaces between steam pipes and process pipes has proven itself over time:

A globe valve for shutting off steam pipes and a diaphragm valve as an interface to the process pipes.

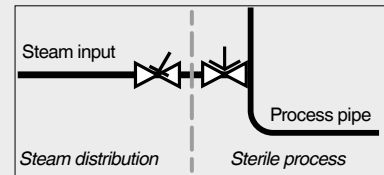

Ambient temperature

0 ... 60 °C

Control medium

Inert gases

Max. permissible temperature of control medium

40 °C

Filling volume

Actuator size	Control function 1	Control function 2
B/N	0.03 dm ³	0.02 dm ³
1/N	0.15 dm ³	0.11 dm ³
2/N	0.26 dm ³	0.23 dm ³
3/N	0.73 dm ³	0.54 dm ³
4/N	2.30 dm ³	1.87 dm ³
5/N	2.30 dm ³	2.00 dm ³

C.f. 3 = for filling volume in open position see c.f. 1, for filling volume in closed position see c.f. 2

Technical data

		Control function 1			Control function 2			Control function 3		
		Operating pressure [bar] / diaphragm material		Control pressure	Operating pressure [bar] / diaphragm material		Control pressure	Operating pressure [bar] / diaphragm material		Control pressure
MG	DN	EPDM/FPM	PTFE	[bar]	EPDM/FPM	PTFE	[bar]	EPDM/FPM	PTFE	[bar]
10	10, 15, 20	10	6	3.5 - 7.0	10	6	max. 6,0	10	6	max. 5.0
25	15, 20, 25	10	6	5.5 - 7.0	10	6	max. 5.5	10	6	max. 5.5
40	32, 40	10	6	5.5 - 7.0	10	6	max. 5.5	10	6	max. 5.5
50	50, 65	10	6	5.5 - 7.0	10	6	max. 5.0	10	6	max. 5.0
80	65, 80	8	5	5.0 - 7.0	8	6	max. 5.0	8	6	max. 4.5
100	100	6	4	5.5 - 7.0	6	4	max. 5.0	6	4	max. 4.5

All pressures are gauge pressures. Operating pressure values were determined with static operating pressure applied on one side of a closed valve. Sealing at the valve seat and atmospheric sealing is ensured for the given values. Information on operating pressures applied on both sides and for high purity media on request. Higher operating pressures on request.

MG = diaphragm size

Kv values [m ³ /h]								
MG	DN	DIN	EN 10357 Series B	EN 10357 Series A	DIN 11850 Series 3	SMS 3008	ASME BPE	ISO 1127 / EN 10357 Series C
		Code 0	Code 16	Code 17	Code 18	Code 37	Code 59	Code 60
10	10	-	2.4	2.4	2.4	-	2.2	3.3
	15	3.3	3.8	3.8	3.8	-	2.2	4.0
	20	-	-	-	-	-	3.8	-
25	15	4.1	4.7	4.7	4.7	-	-	7.4
	20	6.3	7.0	7.0	7.0	-	4.4	13.2
	25	13.9	15.0	15.0	15.0	12.6	12.2	16.2
40	32	25.3	27.0	27.0	27.0	26.2	-	30.0
	40	29.3	30.9	30.9	30.9	30.2	29.5	32.8
50	50	46.5	48.4	48.4	48.4	51.7	50.6	55.2
	65	-	-	-	-	62.2	61.8	-
80	65	-	-	77.0	-	68.5	68.5	96.0
	80	-	-	111.0	-	80.0	87.0	111.0
100	100	-	-	194.0	-	173.0	188.0	214.0

Kv values determined acc. to DIN EN 60534, inlet pressure 5 bar, Δp 1 bar, stainless steel valve body and soft elastomer diaphragm.

The Kv values for other product configurations (e.g. other diaphragm or body materials) may differ. In general, all diaphragms are subject to the influences of pressure, temperature, the process and their tightening torques. Therefore the Kv values may exceed the tolerance limits of the standard.

MG = diaphragm size

Technical data

Control pressure / operating pressure diagram

Control function 2 + 3 with elastomer diaphragm

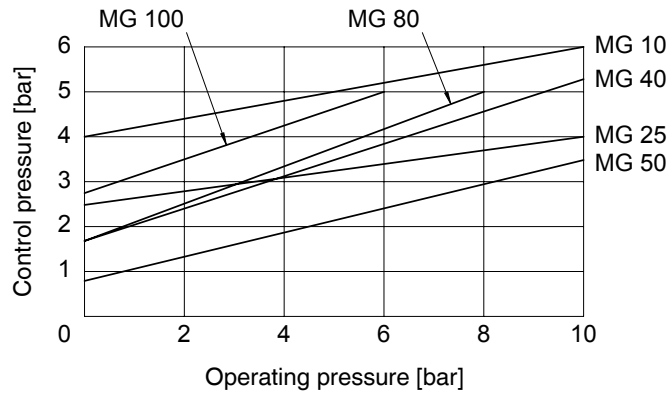

Control function 2 + 3 with PTFE diaphragm

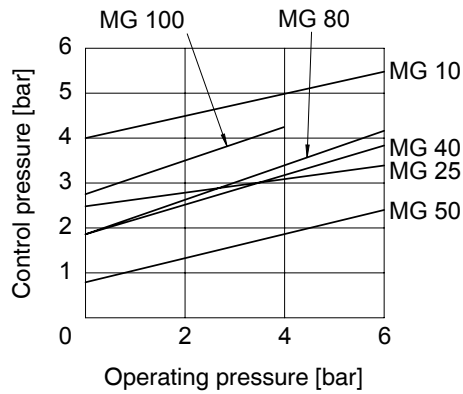

The control pressure depending on the prevailing operating pressure, as shown in the diagram, is intended as a guide for operating the system with low wear on the diaphragm.

Order data

Body configuration	Code
Tank bottom valve body	B**
2/2-way body	D
Multi-port design	M**
T body	T*
* For dimensions see T Valves brochure	
** Dimensions and versions on request or according to customer requirements	

Connection	Code
Butt weld spigots	
Spigots DIN	0
Spigots EN 10357 series B	16
Spigots EN 10357 series A	17
Spigots DIN 11850 series 3	18
Spigots DIN 11866 series A	1A
Spigots DIN 11866 series B	1B
Spigots JIS-G 3447	35
Spigots JIS-G 3459	36
Spigots SMS 3008	37
Spigots BS 4825 part 1	55
Spigots ASME BPE	59
Spigots ISO 1127 / EN 10357 series C	60
Spigots ANSI/ASME B36.19M Schedule 10s	63
Spigots ANSI/ASME B36.19M Schedule 40s	65
Threaded connections	
Threaded sockets DIN ISO 228	1
Threaded sockets NPT	31
Threaded spigots DIN 11851	6
One side threaded spigot, other side cone spigot and union nut, DIN 11851	62
Aseptic unions on request	
Flanges	
Flanges EN 1092 / PN16 / form B, length EN 558, series 1, ISO 5752, basic series 1	8
Flanges ANSI Class 150 RF length MSS SP-88	38
Flanges ANSI Class 125/150 RF length EN 558, series 1 ISO 5752, basic series 1	39
Clamp connections	
Clamps ASME BPE for pipe ASME BPE, length ASME BPE	80
Clamps DIN 32676 series B for pipe EN ISO 1127, length EN 558, series 7	82
Clamps ASME BPE for pipe ASME BPE, length EN 558, series 7	88
Clamps DIN 32676 series A for pipe DIN 11850, length EN 558, series 7	8A
Clamps SMS 3017 for pipe SMS 3008, length EN 558, series 7	8E
Aseptic clamps on request	
For overview of available valve bodies for GEMÜ 687 see page 13	

Valve body material	Code
EN-GJS-400-18-LT (SG iron 40.3) PFA lined	17
EN-GJS-400-18-LT (SG iron 40.3) PP lined	18
1.4435 - BN2 (CF3M), investment casting Fe<0.5%	32
1.4435 (ASTM A 351 CF3M \triangle 316L) investment casting	34
1.4408, investment casting	37
1.4408, PFA lined	39
1.4435 (316L), forged body	40
1.4435 (BN2), forged body Fe<0.5%	42
EN-GJS-400-18-LT (SG iron 40.3) hard rubber lined	83
1.4539, forged body	F4

Diaphragm material	Code
FPM	4
EPDM	13
EPDM	14
EPDM	17
PTFE/EPDM convex, PTFE loose	5E
PTFE/EPDM, PTFE lamin.	52
For compatibility see overview on page 12	
Material complies with FDA requirements, except code 4 and 14	
The combination of PFA lining with 5E diaphragms is only conditionally suitable for gaseous media. If low seat leakage rates are required for gaseous media, other combinations are preferable.	

Control function	Code
Normally closed (NC)	1
Normally open (NO)	2
Double acting (DA)	3

Actuator version	Code
Diaphragm size 10	B/N
Diaphragm size 25	1/N
Diaphragm size 40	2/N
Diaphragm size 50	3/N
Diaphragm size 80	4/N
Diaphragm size 100	5/N
Diaphragm size 25 Control air connector in-line with flow direction	1RN
Diaphragm size 40 Control air connector in-line with flow direction	2RN
Diaphragm size 50 Control air connector in-line with flow direction	3RN
Diaphragm size 80 Control air connector in-line with flow direction	4RN
Diaphragm size 100 Control air connector in-line with flow direction	5RN

Order data

Valve body surface finish, internal contour

	Hygienic class DIN 11866	Designation ASME BPE (2014)	Forged body Code 40, 42, F4	Investment casting Code 32, 34	Code
Ra ≤ 6,3 µm (250 µinch) for media wetted surfaces, blasted internal/external	-	-	-	X	1500
Ra ≤ 0,8 µm (30 µinch) for media wetted surfaces, mechanically polished internal	H3	SF3	X	X	1502
Ra ≤ 0,8 µm (30 µinch) for media wetted surfaces, electropolished internal/external	HE3	-	X	-	1503
Ra ≤ 0,6 µm (25 µinch) for media wetted surfaces, mechanically polished internal	-	SF2	X*	X*	1507
Ra ≤ 0,6 µm (25 µinch) for media wetted surfaces, electropolished internal/external	-	SF6	X*	-	1508
Ra ≤ 0,5 µm (20 µinch) for media wetted surfaces, mechanically polished internal	-	SF1	X*	-	1927
Ra ≤ 0,5 µm (20 µinch) for media wetted surfaces, electropolished internal/external	-	SF5	X*	-	1928
Ra ≤ 0,4 µm (15 µinch) for media wetted surfaces, mechanically polished internal	H4	-	X*	-	1536
Ra ≤ 0,4 µm (15 µinch) for media wetted surfaces, electropolished internal/external	HE4	-	X*	-	1537
Ra ≤ 0,4 µm (15 µinch) for media wetted surfaces, electropolished internal/external	-	SF4	X*	-	1929
Ra ≤ 0,25 µm (10 µinch) for media wetted surfaces, electropolished internal/external	HE5	-	X*	-	1516
Ra ≤ 0,25 µm (10 µinch) for media wetted surfaces, mechanically polished internal	H5	-	X*	-	1527

Ra acc. to DIN 4768; at defined reference points.

* For pipe inside diameter < 6 mm, the surface inside the spigot is Ra ≤ 0.8 µm.

Order data

Special function	Code
3-A compliant design	M

Order example	687	25	D	60	40	5E	1	1/N	1503	M
Type	687									
Nominal size		25								
Body configuration (code)			D							
Connection (code)				60						
Valve body material (code)					40					
Diaphragm material (code)						5E				
Control function (code)							1			
Actuator version (code)								1/N		
Surface finish (code)									1503	
Special function (code)										M

Dimensions [mm]

Actuator dimensions - control function 1 [mm]

MG	Actuator size	ø B	B1	A	A1	G	Weight [kg]
10	B/N	67	44	125	62	G 1/4	0.53
25	1/N	128	-	164	65	G 1/4	2.00
40	2/N	158	-	204	86	G 1/4	3.90
50	3/N	213	-	244	97	G 1/4	7.00
80	4/N	259	-	368	173	G 1/4	15.00
100	5/N	259	-	372	169	G 1/4	16.10

MG = diaphragm size

Actuator dimensions - control functions 2 + 3 [mm]

MG	Actuator size	ø B	A	A1	A2	B1	B2	G
10	B/N	57	110	49	30	35	68	G 1/4
25	1/N	128	117	66	28	-	-	G 1/4
40	2/N	158	143	84	27	-	-	G 1/4
50	3/N	213	167	96	28	-	-	G 1/4
80	4/N	258	282	170	45	-	-	G 1/4
100	5/N	258	278	165	45	-	-	G 1/4

MG = diaphragm size

Control function 1 - Diaphragm size 10

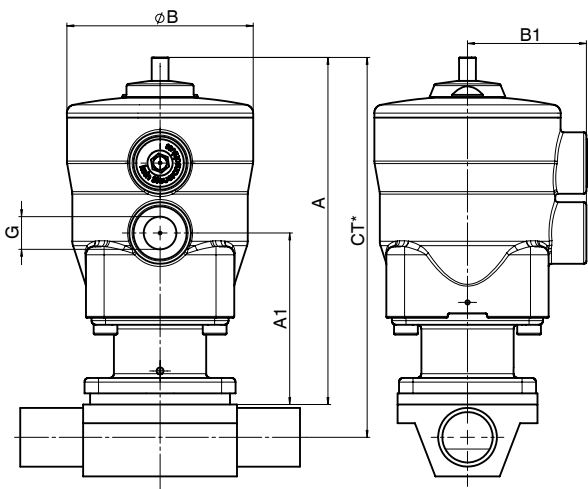

Control functions 2+3 - Diaphragm size 10

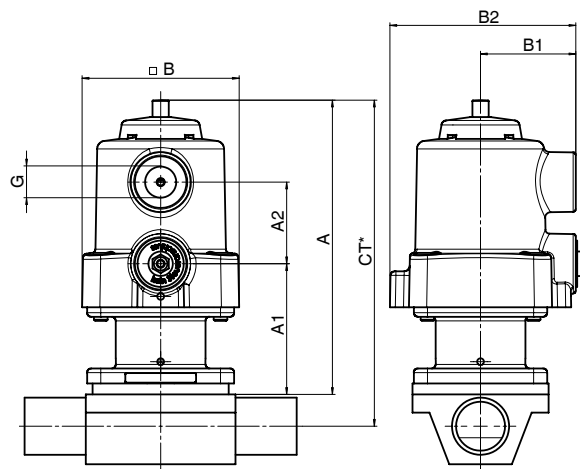

Control function 1 - Diaphragm size 25 - 100

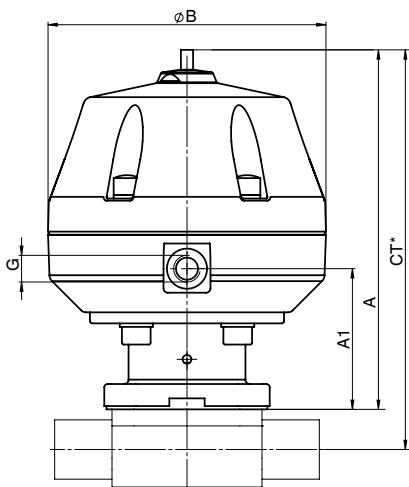

Control functions 2+3 - Diaphragm size 25 - 100

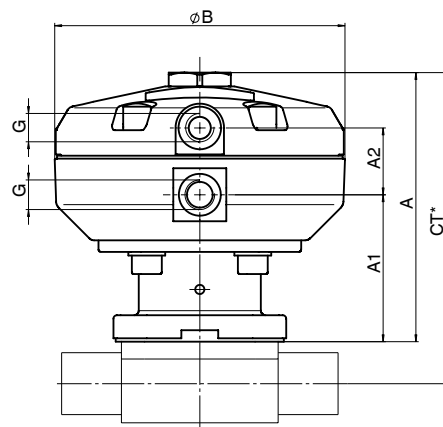

* CT = A + H1 (see body dimensions)

Body dimensions [mm]

Threaded sockets, connection code 1 Valve body material: Investment casting (code 37)

MG	DN	R	L	H	H1	t	SW2	Number of flats	Weight [kg]
10	12	G 3/8	55	25	13	12	22	2	0.17
	15	G 1/2	68	30	15	15	27	2	0.26
25	15	G 1/2	85	29	16	15	27	6	0.32
	20	G 3/4	85	32	16	16	32	6	0.34
	25	G 1	110	37	16	13	41	6	0.39
40	32	G 1 1/4	120	49	24	20	50	8	0.88
	40	G 1 1/2	140	52	24	18	55	8	0.93
50	50	G 2	165	68	33	26	70	8	1.56

MG = diaphragm size

Threaded sockets, connection code 31 Valve body material: Investment casting (code 37)

MG	DN	R	L	H	H1	t	SW2	Number of flats	Weight [kg]
25	15	NPT 1/2	85	29	16	14	27	6	0.32
	20	NPT 3/4	85	32	16	14	32	6	0.34
	25	NPT 1	110	42	21	17	41	6	0.39
40	32	NPT 1 1/4	120	49	24	17	50	8	0.88
	40	NPT 1 1/2	140	52	24	17	55	8	0.93
50	50	NPT 2	165	68	33	18	70	8	1.56

MG = diaphragm size

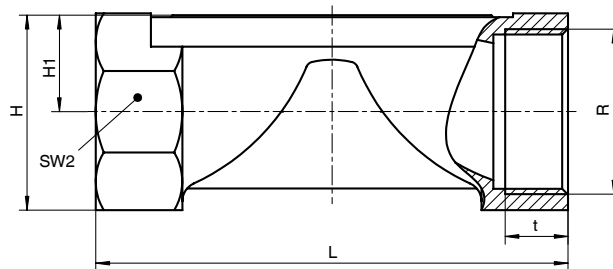

Body dimensions [mm]

Butt weld spigots, connection code 0, 16, 17, 18 Valve body material: Investment casting (code 34), forged body (code 40, F4)

									DIN Series 0 code 0		EN 10357 Series B code 16		EN 10357 Series A code 17		DIN 11850 Series 3 code 18		Weight [kg]
MG	DN	NPS	f*	øg*	L	c	H1*	H1**	ød	s	ød	s	ød	s	ød	s	
10	10	3/8"	30	13.5	108	25	12.5		-	-	12	1.0	13	1.5	14	2.0	0.30
	15	1/2"	30	13.5	108	25	12.5		18	1.5	18	1.0	19	1.5	20	2.0	0.30
	20	3/4"	30	13.5	108	25	12.5		-	-	-	-	-	-	-	-	0.30
25	15	1/2"	40	13.5	120	25	13.0	19.0	18	1.5	18	1.0	19	1.5	20	2.0	0.62
	20	3/4"	40	13.5	120	25	16.0	19.0	22	1.5	22	1.0	23	1.5	24	2.0	0.58
	25	1"	40	13.5	120	25	19.0	19.0	28	1.5	28	1.0	29	1.5	30	2.0	0.55
40	32	1 1/4"	68	13.5	153	25	24.0	26.0	34	1.5	34	1.0	35	1.5	36	2.0	1.45
	40	1 1/2"	75	13.5	153	25	26.0	26.0	40	1.5	40	1.0	41	1.5	42	2.0	1.32
50	50	2"	90	13.5	173	30	32.0	32.0	52	1.5	52	1.0	53	1.5	54	2.0	2.25
80	65	2 1/2"	-	-	216	30	-	62.0	-	-	-	-	70	2.0	-	-	8.60
	80	3"	-	-	254	30	-	62.0	-	-	-	-	85	2.0	-	-	8.00
100	100	4"	-	-	305	30	-	76.0	-	-	-	-	104	2.0	-	-	24.10

* only for investment cast design

** only for forged design

MG = diaphragm size

For materials see overview on page 12

Butt weld spigots, connection code 1A, 1B, 60 Valve body material: Investment casting (code 34), forged body (code 40, F4)

									DIN 11866 Series A code 1A		DIN 11866 Series B code 1B		ISO 1127 / EN 10357 Series C code 60		Weight [kg]
MG	DN	NPS	f*	øg*	L	c	H1*	H1**	ød	s	ød	s	ød	s	
10	10	3/8"	30	13.5	108	25	12.5		13	1.5	17.2	1.6	17.2	1.6	0.30
	15	1/2"	30	13.5	108	25	12.5		19	1.5	21.3	1.6	21.3	1.6	0.30
	20	3/4"	30	13.5	108	25	12.5		-	-	-	-	-	-	0.30
25	15	1/2"	40	13.5	120	25	13.0	19.0	19	1.5	21.3	1.6	21.3	1.6	0.62
	20	3/4"	40	13.5	120	25	16.0	19.0	23	1.5	26.9	1.6	26.9	1.6	0.58
	25	1"	40	13.5	120	25	19.0	19.0	29	1.5	33.7	2.0	33.7	2.0	0.55
40	32	1 1/4"	68	13.5	153	25	24.0	26.0	35	1.5	42.4	2.0	42.4	2.0	1.45
	40	1 1/2"	75	13.5	153	25	26.0	26.0	41	1.5	48.3	2.0	48.3	2.0	1.32
50	50	2"	90	13.5	173	30	32.0	32.0	53	1.5	60.3	2.0	60.3	2.0	2.25
80	65	2 1/2"	-	-	216	30	-	62.0	70	2.0	76.1	2.0	76.1	2.0	8.60
	80	3"	-	-	254	30	-	62.0	85	2.0	88.9	2.3	88.9	2.3	8.00
100	100	4"	-	-	305	30	-	76.0	104	2.0	114.3	2.3	114.3	2.3	24.10

* only for investment cast design

** only for forged design

MG = diaphragm size

For materials see overview on page 12

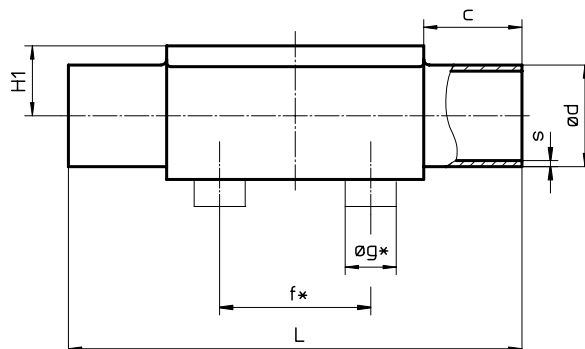

Body dimensions [mm]

Butt weld spigots, connection code 35, 36, 37 Valve body material: Investment casting (code 34), forged body (code 40, F4)

MG	DN	NPS	f*	øg*	L	c	H1*	H1**	JIS-G 3447 code 35		JIS-G 3459 code 36		SMS 3008 code 37		Weight [kg]
									ød	s	ød	s	ød	s	
10	10	3/8"	30	13.5	108	25	12.5		-	-	17.3	1.65	-	-	0.30
	15	1/2"	30	13.5	108	25	12.5		-	-	21.7	2.10	-	-	0.30
	20	3/4"	30	13.5	108	25	12.5		-	-	-	-	-	-	0.30
25	15	1/2"	40	13.5	120	25	13.0	19.0	-	-	21.7	2.10	-	-	0.62
	20	3/4"	40	13.5	120	25	16.0	19.0	-	-	27.2	2.10	-	-	0.58
	25	1"	40	13.5	120	25	19.0	19.0	25.4	1.2	34.0	2.80	25.0	1.2	0.55
40	32	1 1/4"	68	13.5	153	25	24.0	26.0	31.8	1.2	42.7	2.80	33.7	1.2	1.45
	40	1 1/2"	75	13.5	153	25	26.0	26.0	38.1	1.2	48.6	2.80	38.0	1.2	1.32
50	50	2"	90	13.5	173	30	32.0	32.0	50.8	1.5	60.5	2.80	51.0	1.2	2.25
	65	2 1/2"	-	-	173	30	-	34.0	63.5	2.0	-	-	63.5	1.6	2.20
80	65	2 1/2"	-	-	216	30	-	62.0	63.5	2.0	76.3	3.00	63.5	1.6	8.60
	80	3"	-	-	254	30	-	62.0	76.3	2.0	89.1	3.00	76.1	1.6	8.00
100	100	4"	-	-	305	30	-	76.0	101.6	2.0	114.3	3.00	101.6	2.0	24.10

* only for investment cast design

** only for forged design

MG = diaphragm size

For materials see overview on page 12

Butt weld spigots, connection code 55, 59, 63, 65 Valve body material: Investment casting (code 34), forged body (code 40, F4)

MG	DN	NPS	f*	øg*	L	c	H1*	H1**	BS 4825 code 55		ASME BPE code 59		ANSI/ASME B36.19M 10s code 63		ANSI/ASME B36.19M 40s code 65		Weight [kg]
									ød	s	ød	s	ød	s	ød	s	
10	10	3/8"	30	13.5	108	25	12.5		9.53	1.2	9.53	0.89	17.1	1.65	17.1	2.31	0.30
	15	1/2"	30	13.5	108	25	12.5		12.70	1.2	12.70	1.65	21.3	2.11	21.3	2.77	0.30
	20	3/4"	30	13.5	108	25	12.5		19.05	1.2	19.05	1.65	-	-	-	-	0.30
25	15	1/2"	40	13.5	120	25	13.0	19.0	-	-	-	-	21.3	2.11	21.3	2.77	0.62
	20	3/4"	40	13.5	120	25	16.0	19.0	19.05	1.2	19.05	1.65	26.7	2.11	26.7	2.87	0.58
	25	1"	40	13.5	120	25	19.0	19.0	-	-	25.40	1.65	33.4	2.77	33.4	3.38	0.55
40	32	1 1/4"	68	13.5	153	25	24.0	26.0	-	-	-	-	42.2	2.77	42.2	3.56	1.45
	40	1 1/2"	75	13.5	153	25	26.0	26.0	-	-	38.10	1.65	48.3	2.77	48.3	3.68	1.32
50	50	2"	90	13.5	173	30	32.0	32.0	-	-	50.80	1.65	60.3	2.77	60.3	3.91	2.25
	65	2 1/2"	-	-	173	30	-	34.0	-	-	63.50	1.65	-	-	-	-	2.10
80	65	2 1/2"	-	-	216	30	-	62.0	-	-	63.50	1.65	73.0	3.05	73.0	5.16	8.60
	80	3"	-	-	254	30	-	62.0	-	-	76.20	1.65	88.9	3.05	88.9	5.49	8.00
100	100	4"	-	-	305	30	-	76.0	-	-	101.60	2.11	114.3	3.05	114.3	6.02	24.10

* only for investment cast design

** only for forged design

MG = diaphragm size

For materials see overview on page 12

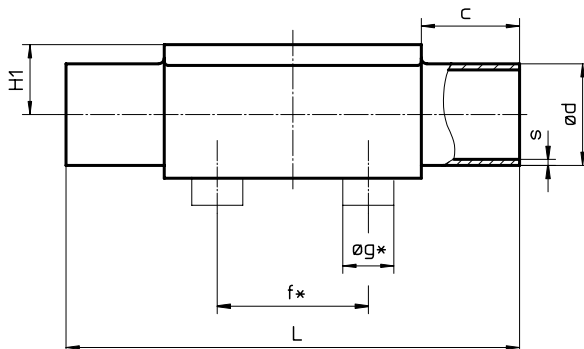

Body dimensions [mm]

Flanges - DIN EN 1092, connection code 8

Valve body material: SG iron 40.3 (code 17, 18, 83), 1.4435 (code 34, 40), 1.4408 (code 39)

MG	DN	øD	øk	øL	Number of bolts	H1			FTF	Weight [kg]
						Material code 17, 18, 39, 83	Material code 34	Material code 40		
25	15	95	65	14	4	18.0	13.0	19.0	130*	1.85
	20	105	75	14	4	20.5	16.0	19.0	150	2.35
	25	115	85	14	4	23.0	19.0	19.0	160	2.85
40	32	140	100	19	4	28.7	24.0	26.0	180	4.90
	40	150	110	19	4	33.0	26.0	26.0	200	5.65
50	50	165	125	19	4	39.0	32.0	32.0	230	7.45
80	65	185	145	19	4	51.0	-	62.0	290	10.20
	80	200	160	19	8	59.5	-	62.0	310	14.20
100	100	220	180	19	8	73.0	-	76.0	350	21.00

*Material code 34, 40 FTF = 150 (no DIN length)

MG = diaphragm size

For materials see overview on page 12

Flanges - ANSI Class 125/150 RF, connection code 38, 39

Valve body material: SG iron 40.3 (code 17, 18, 83), 1.4435 (code 34, 40), 1.4408 (code 39)

MG	DN	øD	øk	øL	Number of bolts	H1			FTF		Weight [kg]
						Material code 17, 18, 39, 83	Material code 34	Material code 40	Connection code 38	Connection code 39	
25	15	90	60.3	15.9	4	18.0	13.0	19.0	-	130	1.85
	20	100	69.9	15.9	4	20.5	16.0	19.0	146	150	2.35
	25	110	79.4	15.9	4	23.0	19.0	19.0	146	160	2.85
40	32	115	88.9	15.9	4	28.7	24.0	26.0	-	180	4.90
	40	125	98.4	15.9	4	33.0	26.0	26.0	175	200	5.65
50	50	150	120.7	19.0	4	39.0	32.0	32.0	200	230	7.45
80	65	180	139.7	19.0	4	51.0	-	62.0	226	290	10.20
	80	190	152.4	19.0	4	59.5	-	62.0	260	310	14.20
100	100	230	190.5	19.0	8	73.0	-	76.0	327	350	21.00

MG = diaphragm size

For materials see overview on page 12

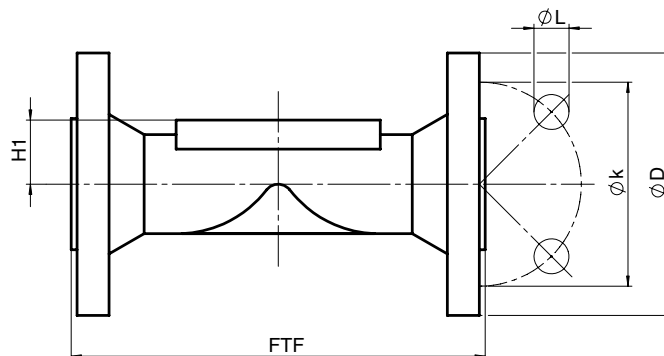

Body dimensions [mm]

Threaded connections, connection code 6, 62
Valve body material: investment casting (code 34), forged body (code 40)

MG	DN	H1*	H1**	f*	øg*	ød1	Thread to DIN 405 R	code 6 L	code 62 L	Weight [kg]
10	10	12.5	-	30.0	13.5	10.0	RD 28 x 1/8	118	116	0.33
	15	12.5	-	30.0	13.5	16.0	RD 34 x 1/8	118	116	0.35
25	15	13.0	19	40.0	13.5	16.0	RD 34 x 1/8	118	116	0.71
	20	16.0	19	40.0	13.5	20.0	RD 44 x 1/6	118	114	0.78
	25	19.0	19	40.0	13.5	26.0	RD 52 x 1/6	128	127	0.79
40	32	24.0	26	68.0	13.5	32.0	RD 58 x 1/6	147	147	1.66
	40	26.0	26	75.0	13.5	38.0	RD 65 x 1/6	160	160	1.62
50	50	32.0	32	90.0	13.5	50.0	RD 78 x 1/6	191	191	2.70
80	65	-	62	-	-	66.0	RD 95 x 1/6	246	246	9.22
	80	-	62	-	-	81.0	RD 110 x 1/4	256	256	9.20

* only for investment cast design

** only for forged design

MG = diaphragm size

For materials see overview on page 12

Code 6

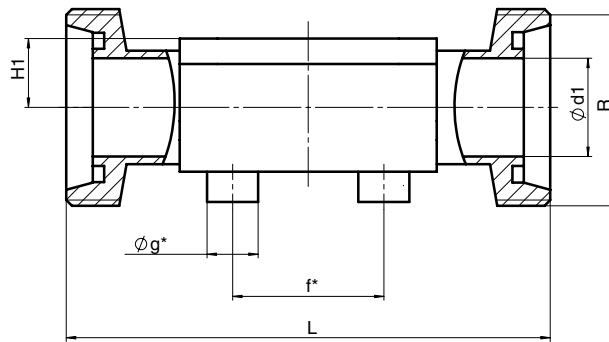

Code 62

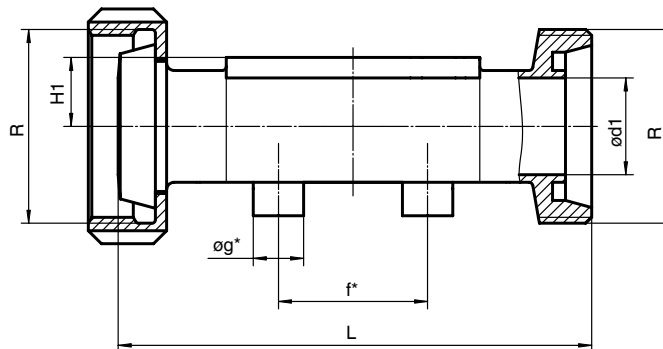

Body dimensions [mm]

Clamp connections, connection code 80, 82, 88, 8A, 8E Valve body material: Forged body (code 40, F4)

MG	DN	NPS	H1	for pipe ASME BPE code 80			for pipe EN ISO 1127 code 82			for pipe ASME BPE code 88			for pipe DIN 11850 code 8A			for pipe SMS 3008 code 8E			Weight [kg]
				ød1	ød3	L	ød1	ød3	L	ød1	ød3	L	ød1	ød3	L	ød1	ød3	L	
10	10	3/8"	12.5	-	-	-	14.0	25.0	108.0	-	-	-	10	34.0	108.0	-	-	-	0.30
	15	1/2"	12.5	9.40	25.0	88.9	18.1	50.5	108.0	9.40	25.0	108	16	34.0	108.0	-	-	-	0.43
	20	3/4"	12.5	15.75	25.0	101.6	-	-	-	15.75	25.0	117	-	-	-	-	-	-	0.43
25	15	1/2"	19.0	-	-	-	18.1	50.5	108.0	-	-	-	16	34.0	108.0	-	-	-	0.75
	20	3/4"	19.0	15.75	25.0	101.6	23.7	50.5	117.0	15.75	25.0	117	20	34.0	117.0	-	-	-	0.71
	25	1"	19.0	22.10	50.5	114.3	29.7	50.5	127.0	22.10	50.5	127	26	50.5	127.0	22.6	50.5	127	0.63
40	32	1 1/4"	26.0	-	-	-	38.4	64.0	146.0	-	-	-	32	50.5	146.0	31.3	50.5	146	1.62
	40	1 1/2"	26.0	34.80	50.5	139.7	44.3	64.0	159.0	34.80	50.5	159	38	50.5	159.0	35.6	50.5	159	1.50
50	50	2"	32.0	47.50	64.0	158.8	56.3	77.5	190.0	47.50	64.0	190	50	64.0	190.0	48.6	64.0	190	2.50
	65	2 1/2"	34.0	60.20	77.5	193.8	-	-	-	60.20	77.5	216	-	-	-	60.3	77.5	216	2.30
80	65	2 1/2"	62.0	60.20	77.5	193.8	72.1	91.0	216.0	60.20	77.5	216	66	91.0	216.0	60.3	77.5	216	8.90
	80	3"	62.0	72.90	91.0	222.3	84.3	106.0	254.0	72.90	91.0	254	81	106.0	254.0	72.9	91.0	254	8.50
100	100	4"	76.0	97.38	119.0	292.1	109.7	130.0	305.0	97.38	119.0	305	100	119.0	305.0	97.6	119.0	305	24.80

MG = diaphragm size

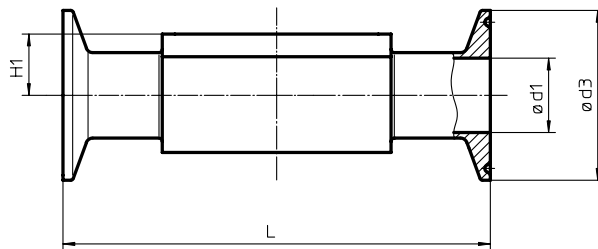

Overview of diaphragm materials for GEMÜ 687

Diaphragm size	Diaphragm material				
	FPM	EPDM	EPDM	EPDM	PTFE/EPDM
10	4	13	14	17	52
25	4	13	14	17	5E
40	4	13	14	17	5E
50	4	13	14	17	5E
80	4	13	14	17	5E
100	4	13	14	17	52

Overview of valve bodies for GEMÜ 687

		Spigots																							
Connection code		0		16		17		18		1A	1B	35		36	37		55		59		60		63	65	
Material code		34	40	34	40	34	40	34	40	40	40	34	40	40	40	34	40	34	40	34	40	34	40	40	40
MG	DN																								
10	10	-	-	X	X	X	X	X	X	X	X	-	-	X	-	-	-	X	-	X	X	X	X	X	X
	15	X	X	X	X	X	X	X	X	X	X	-	-	X	-	-	X	X	-	X	X	X	X	X	X
	20	-	-	-	-	-	-	-	-	-	-	-	-	-	-	-	X	X	X	X	-	-	-	-	-
25	15	X	X	X	X	X	X	-	X	X	X	-	-	X	-	-	-	-	-	-	X	X	X	X	
	20	X	X	X	X	X	X	-	X	X	X	-	-	X	-	-	X	X	X	X	X	X	X	X	
	25	X	X	X	X	X	X	X	X	X	X	X	X	X	X	X	-	-	X	X	X	X	X	X	
40	32	X	X	X	X	X	X	X	X	X	X	X	X	X	X	X	-	-	-	-	X	X	X	X	
	40	X	X	X	X	X	X	X	X	X	X	X	X	X	X	X	-	-	X	X	X	X	X	X	
50	50	X	X	X	X	X	X	X	X	X	X	X	X	X	X	X	-	-	X	X	X	X	X	X	
	65	-	-	-	-	-	-	-	-	-	-	-	X	-	-	X	-	-	-	X	-	-	-	-	
80	65	-	-	-	-	-	X	-	-	X	X	-	X	X	-	X	-	-	-	X	-	X	X	X	
	80	-	-	-	-	-	X	-	-	X	X	-	X	X	-	X	-	-	-	X	-	X	X	X	
100	100	-	-	-	-	-	X*	-	-	X*	X*	-	X*	X*	-	X*	-	-	-	X*	-	X*	X*	X*	

*Valve bodies are not suitable for use with diaphragms code 5E.

Availability of material code 32: same as code 34, availability of material code 42, F4: same as code 40

MG = diaphragm size

		Threaded connections					Clamps					Flanges															
Connection code		1	31	6	62	80	82	88	8A	8E	8					38					39						
Material code		37	37	34	40	34	40	40	40	40	17	18	34	39	40	83	17	18	39	83	17	18	34	39	40	83	
MG	DN																										
10	10	-	-	W	W	W	W	-	K	-	K	-	-	-	-	-	-	-	-	-	-	-	-	-	-		
	12	X	-	-	-	-	-	-	-	-	-	-	-	-	-	-	-	-	-	-	-	-	-	-	-		
	15	X	-	W	W	W	W	K	W	K	K	-	-	-	-	-	-	-	-	-	-	-	-	-	-		
25	20	-	-	-	-	-	K	-	K	-	-	-	-	-	-	-	-	-	-	-	-	-	-	-	-		
	15	X	X	W	W	W	W	-	W	-	K	-	X	X	W	X	W	X	-	-	-	-	X	X	W	X	
	20	X	X	W	W	W	W	K	K	K	K	-	X	X	W	X	W	X	X	X**	X	X	X	X	W	X	
40	25	X	X	W	W	W	W	K	K	K	K	X	X	W	X	W	X	X	X**	X	X	X	X	W	X		
	32	X	X	W	W	W	W	-	W	-	K	K	X	X	W	X	W	X	-	-	-	-	X	X	W	X	
50	40	X	X	W	W	W	W	K	W	K	K	K	X	X	W	X	W	X	X	X**	X	X	X	W	X		
	50	X	X	W	W	W	W	K	W	K	K	K	X	X	W	X	W	X	X	X**	X	X	X	W	X		
80	65	-	-	-	-	-	W	-	W	-	W	-	-	-	-	-	-	-	-	-	-	-	-	-	-		
	65	-	-	-	-	-	W	-	W	K	K	K	K	-	-	-	-	W	-	-	-	-	-	-	W	-	
100	80	-	-	-	W	-	W	K	W	K	W	K	X	X	-	X	W	X	X	X**	X	X	X	-	X	W	X
	80	-	-	-	W	-	W	K	W	K	W	K	X	X	-	X	W	X	X	X**	X	X	X	-	X	W	X
100	100	-	-	-	-	-	W*	W*	W*	W*	W*	X	X	-	X	W*	X	X	X**	X	X	X	X	-	X	W*	X

* Valve bodies are not suitable for use with diaphragms code 5E.

** Connection code 38 / material code 18 on request

X = Standard K = Connections completely machined (not welded) W = Welded construction

Availability of material code 32: same as code 34, availability of material code 42, F4: same as code 40

MG = diaphragm size

For further metal diaphragm valves, accessories and other products, please see our Product Range catalogue and Price List. Contact GEMÜ.

GEMÜ® VALVES, MEASUREMENT AND CONTROL SYSTEMS

