

I Application

Butterfly valves, whether manually or automatically operated, can be used in most liquid product applications in the food-processing, pharmaceutical and chemical industries.

I Operating principle

The butterfly valve can be operated automatically through an actuator or manually with a handle.

The handle blocks the valve in the "open" or "closed" position, although there are also other models with intermediate positions.

The actuator transforms the axial movement of the piston into a 90° rotary movement which it transmits to the disc.

I Design and features

Compact and robust design.

Multi-position handle as standard feature for valves up to 4".

Two-position handle as standard feature for valves starting from 4".

Several models of easily interchangeable manual handles and pneumatic or electric actuators.

Low pressure losses.

Body halves interchangeable with any connection type.

Standard connections: Clamp.

Traceability of components.

I Materials

Disc and body halves	AISI 316L (forged)
Handle	AISI 304 / PP
Other st. st. parts	AISI 304
Gasket	EPDM according to FDA 177.2600
Internal surface finish	Ra ≤ 0,8 μm
External surface finish	Machined

I Options

Valve in AISI 304L.

Gaskets: NBR, VMQ or FPM.

Connections: weld, DIN, SMS, RJT, FIL-IDF, etc.

Two sizes for multi-position handle.

Handles: two-position, lever, micrometric, with safety lock, etc.

Electric actuator or single- or double-acting actuator, the size is determined by the operating torque of the valve.

Electro-pneumatic positioner.

Inductive position sensors.

C-TOP control unit (inductive position sensors or microswitches).

ATEX version available.



Distributed by:

Tri-Canada

7033 Telford Way #20, Mississauga, ON L5S 1V4

Tel: 905.677.9000 • Toll Free: 1.800.486.7863

www.tricanada.com

I Technical specifications

Available sizes DN ½" - DN 8"
 Max. working temperature -14 °F to 248 °F
 284 °F
 Min. working pressure 3 PSI (P.abs)
 Max. working pressure 145 PSI (DN ½" - DN 4") ⁽¹⁾
 116 PSI (DN 5" - DN 6") ⁽²⁾
 72,5 PSI (DN 8") ⁽²⁾

Note (1): Classified according to Directive 97/23/CE as Category I valves for use with fluids of Group 1
 Note (2): Classified according to Directive 97/23/CE as Category I valves for use with fluids of Group 2

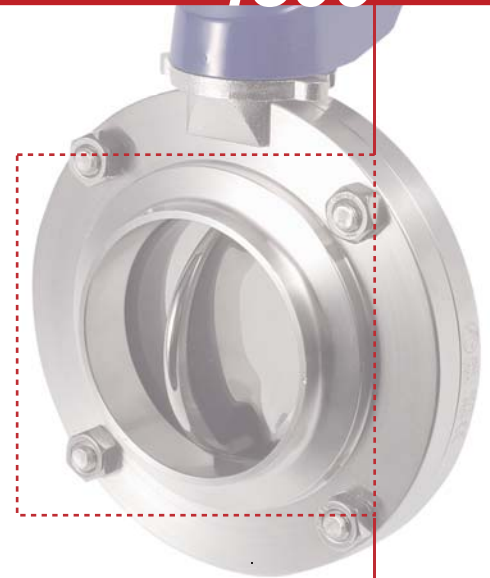

	½"	¾"	1"	1½"	2"	2½"	3"	4"	5"	6"	8"
OPERATING TORQUE (Lb.ft)	4	4	6	7	10	11	13	18	41	52	66

Test pressure 145 PSI

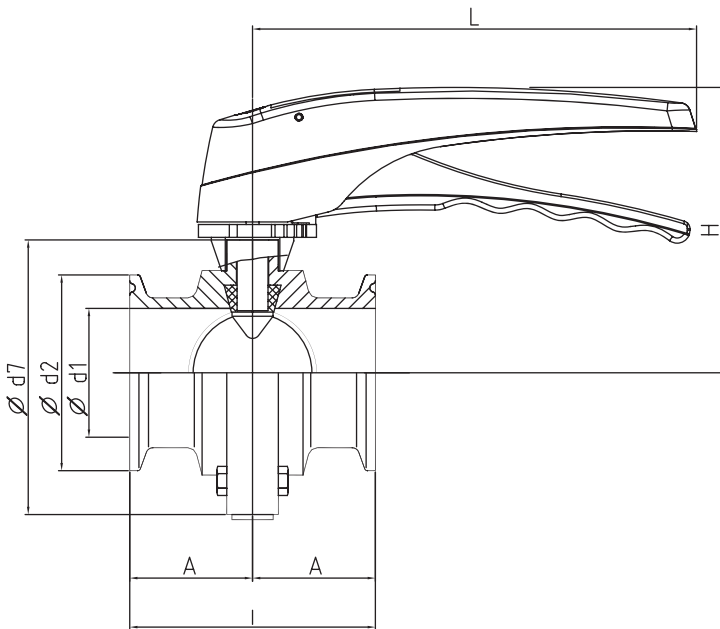

DN	Ø d1	Ø d2	d7	A	I	H	L
½" ⁽¹⁾	0,37	1	2,44	1,10	2,20	3,5	4,53
¾" ⁽¹⁾	0,62	1	2,44	1,10	2,20	3,5	
1" ⁽¹⁾	0,87	2	3,43	1,26	2,52	4	
1½"	1,37	2	3,82	1,42	2,84	4,19	6,69
2"	1,87	2,52	4,33	1,42	2,84	4,53	
2 ½"	2,37	3,05	4,65	1,50	3	4,61	
3"	2,87	3,58	5,16	1,50	3	4,92	
4"	3,83	4,70	6,38	1,85	3,70	5,63	10,63
5" ⁽²⁾	4,84	5,70	7,52	2,20	4,40	5,85	
6" ⁽²⁾	5,78	6,54	9,45	2,6	5,2	7,09	
8" ⁽²⁾	7,77	8,60	11,8	2,1	4,2	8,07	

(1) Mini handle
 (2) Two-position handle



The information contained in this brochure is for guidance only. We reserve the right to modify any material or feature without notice in advance. For further information, please, consult our web site. www.inoxpa.com

