

Distributed by:

**Tri-Canada**

7033 Telford Way #20, Mississauga, ON L5S 1V4  
Tel: 905.677.9000 • Toll Free: 1.800.486.7863  
[www.tricanada.com](http://www.tricanada.com)

**GEMÜ®**

VALVES, MEASUREMENT AND  
CONTROL SYSTEMS

## *2/2-Way and T Valve Bodies in Stainless Steel*





**Leading the world in pharmaceutical and biotechnology industry sterilisation processes**

GEMÜ is one of the leading manufacturers of valves, measurement and control systems and is the world market leader for sterile valve applications in the pharmaceutical and biotechnology industries. This position is based on GEMÜ's comprehensive investments in application-oriented research & development, amounting to more than 5% of the company's turnover.

**Customized solutions for your project business**

GEMÜ provides the optimal solution from a single source.

As a system supplier of isolation, actuator and control technology, we can respond very flexibly to your individual project-specific needs.

Our worldwide sales network provides fast reaction times, customer oriented service and a committed project management team.



# Table of contents



## 2/2-Way Valve Bodies

Description of use	4	Clamp DIN 32676, code 8A - butt weld spigot DIN 11850 series 2, code 17	33
Material selection	5	Clamp DIN 32676, code 8A - butt weld spigot DIN 11850 series 3, code 18	34
Grades of surface finish	6	Clamp IDF/ISO for JIS-G 3447 pipes, code 8F - butt weld spigot JIS-G 3447, code 35	35
Butt weld connections	7	Clamp IDF/ISO for JIS-G 34597 pipes, code 8H - butt weld spigot JIS-G 3459, code 36	36
Selection of operators	8 - 10	Clamp SMS 3017, length EN 558-1 series 7, code 8E - butt weld spigot SMS 3008, code 37	37
Butt weld spigots for EN ISO 1127 pipes , code 60	11	Aseptic clamps	38
Butt weld spigots for DIN pipes, code 0	12	Dairy pipe and aseptic unions	39
Butt weld spigots for DIN 11850 pipes, series 1, code 16	13	Aseptic flanges	40
Butt weld spigots for DIN 11850 pipes, series 2, code 17; DIN 11866, series A, code 1A	14	Kv value	41
Butt weld spigots for DIN 11850 pipes, series 3, code 18	15	Order code	42
Butt weld spigots for ASME BPE pipes, code 59	16	Angle of rotation for optimum draining	43
Butt weld spigots for BS 4825 pipes, code 55	17	GEMÜ angle gauge	44
Butt weld spigots for JIS-G 3447 pipes, code 35	18		
Butt weld spigots for JIS-G 3459 pipes, code 36	19		
Butt weld spigots for SMS 3008 pipes, code 37	20		
Clamp bodies	21		
Clamps ASME BPE for ASME BPE pipes, short design, code 80	22	<b>T valve bodies</b>	
Clamps following ASME BPE for EN ISO 1127 pipes, code 82	23	Description of use	45
Clamps ASME BPE for ASME BPE pipes, code 88	24	Material selection	46
Clamps DIN 32676 for DIN 11850 pipes, code 8A	25	Grades of surface finish	47
Clamps SMS 3017 for SMS 3008 pipes, code 8E	26	T valve bodies for sampling, body version "A"	48
Clamps IDF/ISO for JIS-G 3447 pipes, code 8F	27	T valve bodies for EN ISO 1127 pipes, DN 6 - DN 150	49 - 51
Clamps IDF/ISO for JIS-G 3459 pipes, code 8H	28	T valve bodies for DIN pipes, DN 6 - DN 150	52 - 55
Clamp ASME BPE (short design), code 80 - butt weld spigot ASME BPE, code 59	29	T valve bodies for ASME - BPE pipes, DN 8 - DN 150	56 - 57
Clamp ASME BPE, length EN 558-1 series 7, code 82 - butt weld spigot EN ISO 1127, code 60	30	T valve bodies for JIS-G3447 pipes, DN 25 - DN 100	58
Clamp ASME BPE, length EN 558-1 series 7, code 88 - butt weld spigot ASME BPE, code 59	31	T valve bodies for JIS-G3459 pipes, DN 6 - DN 100	59 - 61
Clamp DIN 32676, code 8A - butt weld spigot DIN 11850 series 1, code 16	32	T valve bodies for SMS 3008 pipes, DN 25 - DN 100	62 - 63
		T valve bodies with clamp connections	64
		Order code	65
		Materials and certificates	66
		GEMÜ manufacturing sites and sales locations worldwide	67

## **Description of use**

### *2/2-way valve bodies*



2/2-way straight through valve bodies are the body versions used most often in industrial applications. Butt weld spigots and clamp connections are the most common connections in sensitive sterile areas

whereas threaded connections, aseptic flanges and threaded sockets only play a secondary role here.

#### **Features**

- *Standard valve body material 1.4435 in investment cast, forged or block material design. 1.4539 and other materials on request*
- *Standard connections are butt weld spigots, clamps and sterile connections, other connections on request*
- *Internal surface contour mechanically polished and/or electropolished down to Ra 0.25 µm*
- *Compact design, GMP-compliant design*
- *Available with manual, pneumatic or motorized operators (modular system)*

# Material selection

## 2/2-way valve bodies



### Investment casting

Material code	32	1.4435 (BN2) Fe < 0.5%
	34	1.4435 (ASTM A 351 CF3M)*

\* Material equivalency 316 L

### Forged body

Material code	40	1.4435 (F316L)
	42	1.4435 (BN2) Fe<0,5%
	F4	1.4539 (F904L)

### Block material

Material code	41	1.4435 (316L/F316L)
	43	1.4435 (BN2) Fe<0,5%

Other valve body materials	Code
1.4539, block material	44
3.7035, titanium	A1
2.4602, block material Hastelloy C 22 (NiCr21Mo14W)	A3

Special materials on request



# Grades of surface finish

## 2/2-way valve bodies

Valve body surface finish, internal contour			
	Forged body - Codes 40, 42, F4 Block material - Codes 41, 43	Investment casting Codes 32, 34	Code
Ra ≤ 0,8 µm (30 µinch) for media wetted surfaces, mechanically polished internal	X	X	1502
Ra ≤ 0,8 µm (30 µinch) for media wetted surfaces, electropolished internal/external	X	-	1503
Ra ≤ 0,6 µm (25 µinch) for media wetted surfaces, mechanically polished internal	X <sup>1</sup>	X <sup>1</sup>	1507
Ra ≤ 0,6 µm (25 µinch) for media wetted surfaces, electropolished internal/external	X <sup>1</sup>	-	1508
Ra ≤ 0,25 µm (10 µinch) for media wetted surfaces, electropolished internal/external	X <sup>1</sup>	-	1516
Ra ≤ 0,25 µm (10 µinch) for media wetted surfaces, mechanically polished internal	X <sup>1</sup>	-	1527
Ra ≤ 0,4 µm (15 µinch) for media wetted surfaces, mechanically polished internal	X <sup>1</sup>	-	1536
Ra ≤ 0,4 µm (15 µinch) for media wetted surfaces, electropolished internal/external	X <sup>1</sup>	-	1537
Ra ≤ 0,5 µm (20 µinch) for media wetted surfaces, mechanically polished internal	X <sup>1</sup>	-	1927
Ra ≤ 0,5 µm (20 µinch) for media wetted surfaces, electropolished internal/external	X <sup>1</sup>	-	1928
Ra ≤ 0,4 µm (15 µinch) for media wetted surfaces, electropolished internal/external	X <sup>1</sup>	-	1929

Ra acc. to DIN 4768; at defined reference points. <sup>1</sup> For pipe inside diameter < 6 mm, the surface inside the spigot is Ra ≤ 0.8 µm.

Modern, ergonomically shaped workstations and trained polishing staff give us the ability to provide high quality surface finishes. Depending on the required application, surface finishes from Ra 0.8 µm down to 0.25 µm can be achieved by polishing, electro polishing or a special process, we call "elysieren".

Mechanical hand polishing is carried out at our works to ensure our high quality standard.

Code	GEMÜ DE	GEMÜ US	DIN 11866		ASME BPE (2014)		
	Ra µm	Ra <sub>max</sub> µinch	Hygiene class	Ra µm	Designation	Ra <sub>max</sub> µinch	Ra µm - converted
1502	≤ 0.8	30	H3	≤ 0.8	SF3	30	0.76
1503	≤ 0.8	30	HE3c	≤ 0.8	-	-	-
1508	≤ 0.6	25	-	-	SF6	25	0.64
1507	≤ 0.6	25	-	-	SF2	25	0.64
1537	≤ 0.4	20	HE4c	≤ 0.4	SF5	20	0.51
1536	≤ 0.4	20	H4	≤ 0.4	SF1	20	0.51
1527	≤ 0.25	15	H5	≤ 0.25	-	-	-
1516	≤ 0.25	15	HE5c	≤ 0.25	SF4	15	0.38

# Butt weld connections

## 2/2-way valve bodies

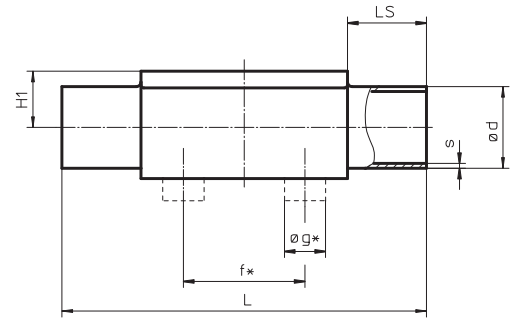

Dimensions in mm

MG	DN	NPS	DIN 11850				DIN 11866				EN ISO 1127		JIS-G 3447		JIS-G 3459		SMS 3008		BS 4825		ASME BPE		ANSI/ASME B36.19M 10s		ANSI/ASME B36.19M 40s					
			Series 0 / Code 0	Series 1 / Code 16	Series 2 / Code 17	Series 3 / Code 18	Series A / Code 1A	Series B / Code 1B	Code 60	Code 35	Code 36	Code 37	Code 55	Code 59	Code 63	Code 65														
8	4	-	6	1.0	-	-	-	-	-	-	-	-	-	-	-	-	-	-	-	-	-	-	-	-	-	-	-			
	6	-	8	1.0	-	-	-	-	-	8	1.0	10.2	1.6	10.2	1.6	-	-	10.5	1.20	-	-	-	-	10.3	1.24	10.3	1.73			
	8	1/4"	10	1.0	-	-	-	-	-	10	1.0	13.5	1.6	13.5	1.6	-	-	13.8	1.65	-	-	6.35	1.2	6.35	0.89	13.7	1.65	13.7	2.24	
	10	3/8"	-	-	12	1.0	13	1.5	14	2.0	13	1.5	-	-	-	-	-	-	-	-	9.53	1.2	9.53	0.89	-	-	-	-		
	15	1/2"	-	-	-	-	-	-	-	-	-	-	-	-	-	-	-	-	-	-	-	12.70	1.2	12.70	1.65	-	-	-	-	
10	10	3/8"	-	-	12	1.0	13	1.5	14	2.0	13	1.5	17.2	1.6	17.2	1.6	-	-	17.3	1.65	-	-	9.53	1.2	9.53	0.89	17.1	1.65	17.1	2.31
	15	1/2"	18	1.5	18	1.0	19	1.5	20	2.0	19	1.5	21.3	1.6	21.3	1.6	-	-	21.7	2.10	-	-	12.70	1.2	12.70	1.65	21.3	2.11	21.3	2.77
	20	3/4"	-	-	-	-	-	-	-	-	-	-	-	-	-	-	-	-	-	-	-	-	19.05	1.2	19.05	1.65	-	-	-	-
25	15	1/2"	18	1.5	18	1.0	19	1.5	20	2.0	19	1.5	21.3	1.6	21.3	1.6	-	-	21.7	2.10	-	-	-	-	-	21.3	2.11	21.3	2.77	
	20	3/4"	22	1.5	22	1.0	23	1.5	24	2.0	23	1.5	26.9	1.6	26.9	1.6	-	-	27.2	2.10	-	-	19.05	1.2	19.05	1.65	26.7	2.11	26.7	2.87
	25	1"	28	1.5	28	1.0	29	1.5	30	2.0	29	1.5	33.7	2.0	33.7	2.0	25.4	1.2	34.0	2.80	25.0	1.2	-	-	25.40	1.65	33.4	2.77	33.4	3.38
40	32	1 1/4"	34	1.5	34	1.0	35	1.5	36	2.0	35	1.5	42.4	2.0	42.4	2.0	31.8	1.2	42.7	2.80	33.7	1.2	-	-	-	42.2	2.77	42.2	3.56	
	40	1 1/2"	40	1.5	40	1.0	41	1.5	42	2.0	41	1.5	48.3	2.0	48.3	2.0	38.1	1.2	48.6	2.80	38.0	1.2	-	-	38.10	1.65	48.3	2.77	48.3	3.68
50	50	2"	52	1.5	52	1.0	53	1.5	54	2.0	53	1.5	60.3	2.0	60.3	2.0	50.8	1.5	60.5	2.80	51.0	1.2	-	-	50.80	1.65	60.3	2.77	60.3	3.91
80	65	2 1/2"	-	-	-	-	70	2.0	-	-	70	2.0	76.1	2.0	76.1	2.0	63.5	2.0	76.3	3.0	63.5	1.6	-	-	63.5	1.65	73.0	3.05	73.0	5.16
	80	3"	-	-	-	-	85	2.0	-	-	85	2.0	88.9	2.3	88.9	2.3	76.3	2.0	89.1	3.0	76.1	1.6	-	-	76.2	1.65	88.9	3.05	88.9	5.49
100	100	4"	-	-	-	-	104	2.0	-	-	104	2.0	114.3	2.3	114.3	2.3	101.6	2.0	114.3	3.0	101.6	2.0	-	-	101.6	2.11	114.3	3.05	114.3	6.02

MG = diaphragm size

\* only for investment cast body

The angles of rotation for installation can be seen from the connection drawings on the following pages.

### The difference between tube specifications (Example DN 15)

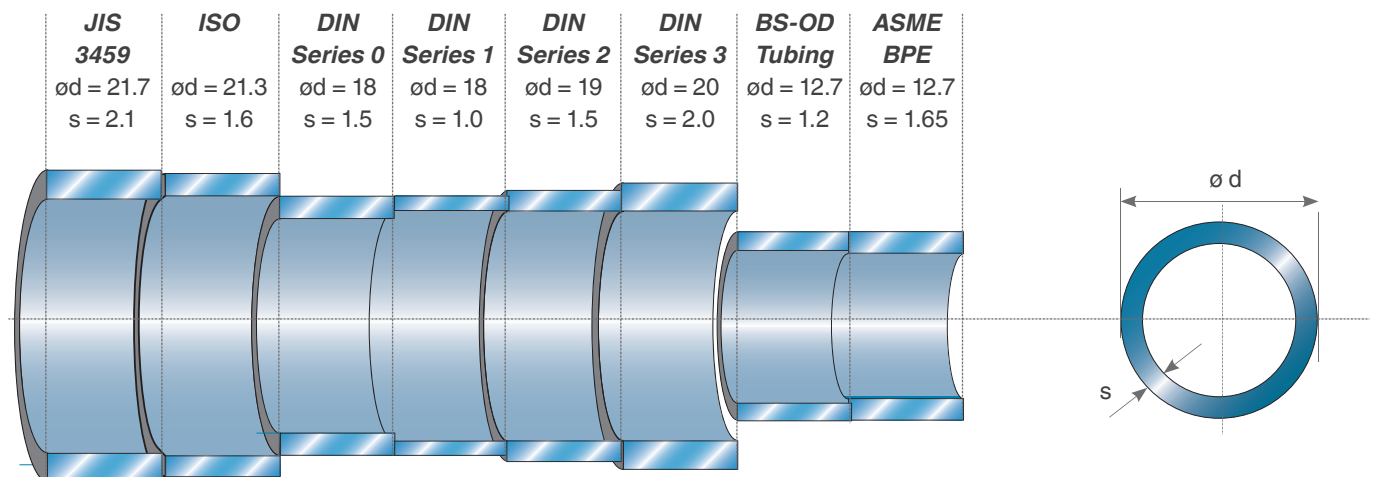

# Selection of operators

## 2/2-way valve bodies

### Manually operated



Type	GEMÜ 9601	GEMÜ 9602	GEMÜ 9612	GEMÜ 9673	GEMÜ 9653	GEMÜ 9654
Material	Stainless steel, plastic handwheel, with optical position indicator and seal adjuster	Stainless steel, with optical position indicator and seal adjuster	Stainless steel, plastic handwheel, with optical position indicator and seal adjuster	Stainless steel, plastic handwheel, with optical position indicator and seal adjuster	Stainless steel, plastic handwheel, with optical position indicator, stroke limiter and seal adjuster, lockable, optional: electrical position indicator	Stainless steel, with optical position indicator, stroke limiter and seal adjuster, lockable, optional: electrical position indicator
Autoclavable	●	●	●	●	●	●
Operating temperature*	-10 to 150 °C	-10 to 150 °C	-10 to 150 °C	-10 to 150 °C	-10 to 150 °C	-10 to 150 °C
Operating pressure*	0 to 10 bar	0 to 10 bar	0 to 10 bar	0 to 10 bar	0 to 10 bar	0 to 10 bar
DN	4 - 15	4 - 15	10 - 20	15 - 50	10 - 100	4 - 100
Diaphragm size 8	●	●	-	-	-	●
Diaphragm size 10	-	-	●	-	●	●
Diaphragm size 25	-	-	-	●	●	●
Diaphragm size 40	-	-	-	●	●	●
Diaphragm size 50	-	-	-	●	●	●
Diaphragm size 80	-	-	-	-	●	●
Diaphragm size 100	-	-	-	-	●	●

\* dependent on diaphragm material, see technical datasheet

### Elastomer diaphragms

EPDM



### PTFE diaphragms

PTFE/EPDM, PTFE/FPM

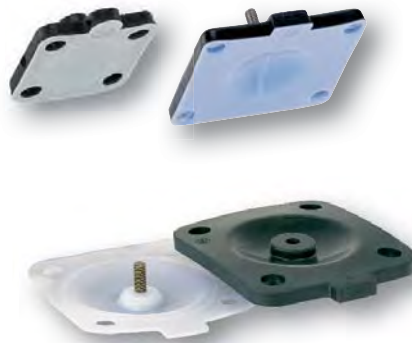



Pneumatically operated



GEMÜ 9605	GEMÜ 9625	GEMÜ 9687	GEMÜ 9650	GEMÜ 9650TL	GEMÜ 9651	GEMÜ 9658/9688	GEMÜ 9660
Plastic, with stainless steel distance piece, optical position indicator	Plastic, with stainless steel distance piece, optical position indicator	Plastic, with stainless steel distance piece, optical position indicator	Stainless steel, with optical position indicator, optionally autoclavable	Safety valve, stainless steel, mounting facility for proximity switches	Stainless steel, with integrated automation module	Two stage actuator, stainless steel	Filling valve, stainless steel with optical position indicator, stroke limiter and seal adjuster
-	-	-	● (DN 4-25)	-	-	-	-
-10 to 150 °C	-10 to 150 °C	-10 to 150 °C	-10 to 150 °C	-10 to 150 °C	-10 to 150 °C	-10 to 150 °C	-10 to 150 °C
0 to 8 bar	0 to 6 bar	0 to 10 bar	0 to 10 bar	0 to 8 bar	0 to 10 bar	0 to 10 bar	0 to 5 bar
4 - 15	10 - 20	10 - 100	4 - 100	4 - 25	4 - 25	10 - 50	4 - 25
●	-	-	●	●	●	●	●
-	●	●	●	●	●	●	●
-	-	●	●	●	●	●	●
-	-	●	●	-	-	●	-
-	-	●	●	-	-	-	-
-	-	●	●	-	-	-	-

Valve body versions



2/2-way body investment casting  
2/2-way version to all international standard butt weld connections



2/2-way body forged version  
2/2-way version to all international standard butt weld connections

Connections



Clamps  
to all common standards



Aseptic clamps  
to all common standards



Aseptic unions  
to all common standards



Aseptic flanges  
to all common standards

Other versions and accessories available. See "Stainless Steel Diaphragm Valves" brochure.

# Selection of operators

## 2/2-way valve bodies

Pneumatically operated

Motorized



Type	GEMÜ 9615	GEMÜ 9695	GEMÜ 9618	GEMÜ 9698
Material	Plastic, with optical position indicator, only for 2/2-way valve bodies	Plastic, with optical position indicator, only for 2/2-way valve bodies	Plastic, with/without stainless steel distance piece, with optical position indicator	Plastic, with stainless steel distance piece, with optical position indicator and manual override
Autoclavable	-	-	-	-
Operating temperature*	-10 to 80 °C	-10 to 80 °C	0 to 130 °C (without distance piece 15 to 50 °C)	-10 to 150 °C
Operating pressure*	0 to 6 bar	0 to 10 bar	0 to 6 bar	0 to 6 bar
DN	10 to 20	15 to 50	4 - 15	15 - 50
Supply voltage	-	-	24 VAC, 120 VAC, 230 VAC, 50/60Hz	24 VAC, 120 VAC, 230 VAC, 50/60Hz
Diaphragm size 8	-	-	●	-
Diaphragm size 10	●	-	●	-
Diaphragm size 25	-	●	-	●
Diaphragm size 40	-	●	-	●
Diaphragm size 50	-	●	-	●
Diaphragm size 80	-	-	-	-
Diaphragm size 100	-	-	-	-

\* dependent on diaphragm material

## Angle of rotation for optimum draining

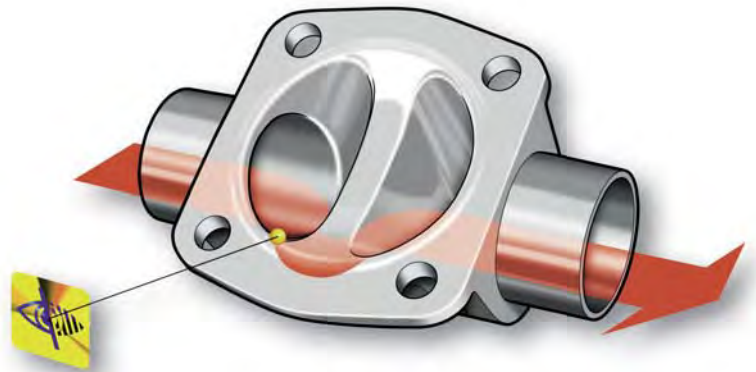
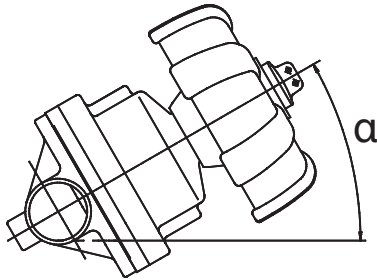

In the pharmaceutical and biotechnological industries and other sensitive industrial sectors the drainability and cleanability of plant plays an important role. Very often plants are cleaned and sterilised after every production process. The objective is to keep the residue as low as possible in order to optimise the sterilisation and cleaning processes of plant and piping systems.

In specialist literature and documents from plant constructors and valve manufacturers the term “self-draining” is often used in this context. It is a fictitious term for the independent emptying of a vessel and/or a pipe section through an opened valve. Depending on a variety of factors it is however not normally possible to expect full drainage without leaving residue even with vertical piping. Therefore the term “self-draining” is often used incorrectly. The term “free outlet”, “unhindered outlet” or “optimum draining” is more realistic. At GEMÜ we use the term optimum draining.

Optimum drainability of a valve depends on several factors:

- *Design of the internal geometry of the valve body*
- *Different pipe standards (ISO, DIN, SMS, ASME BPE, JIS etc.), as they have different inside diameters at the same nominal size*
- *Installation position in the pipeline with regard to horizontal rotation and vertical inclination*
- *Viscosity and adhesive qualities of the medium/media*

Diaphragm valves offer the best structural conditions for an unhindered outlet of the working medium when the valve is open. In an ideal case, the pipe and the valve are vertical. However, if the pipe is horizontal, the valve must be turned axially in the pipe until the outermost point of the sealing weir corresponds to the lowest point of the connecting pipe. Thus the working medium can optimally flow around the weir. The only way to gain the necessary viewing point to set the rotation angle is to remove the operator (manual bonnet or actuator) prior to installing the valve. Optical alignment is often sufficient – it must be noted, however, that the eyes of the viewer must be in line with the transition of the weir and the lowest point of the pipe. Dependent on the viscosity of the working medium or the required outlet velocity, the pipe runs should have a corresponding gradient (pipe inclination).

GEMÜ has calculated draining angles for the various nominal sizes and pipe standards in order to facilitate installation of valves for optimised draining. The draining angles mentioned are valid for installation in horizontal pipe systems. The GEMÜ angle  $\alpha$  is quoted from when the valve is lying on its side with a vertical weirplate and the rotation angle is UPWARDS. Please note the drawing. (Attention: Other manufacturers quote the angle using a horizontal weirplate from the vertical centreline downwards).

The draining angles mentioned in this brochure are valid for valve bodies produced in the EU. Please contact your local supplier for further information.

The values of the draining angles are only provided as a guide without tolerances. Drainability in a plant is the responsibility of the plant designer, plant constructor and end user due to factors described previously.

# GEMÜ angle gauge

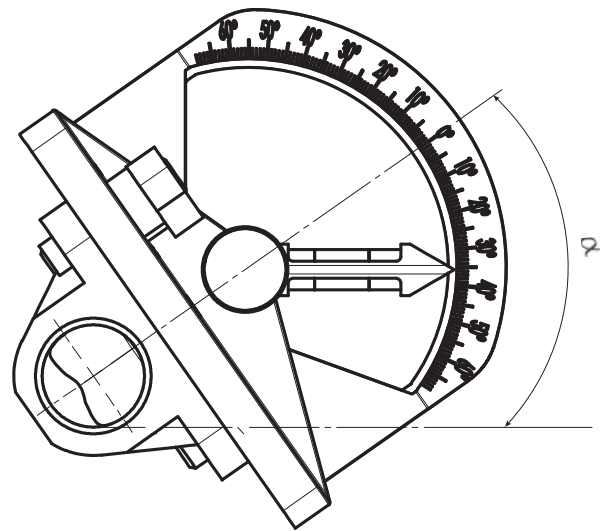
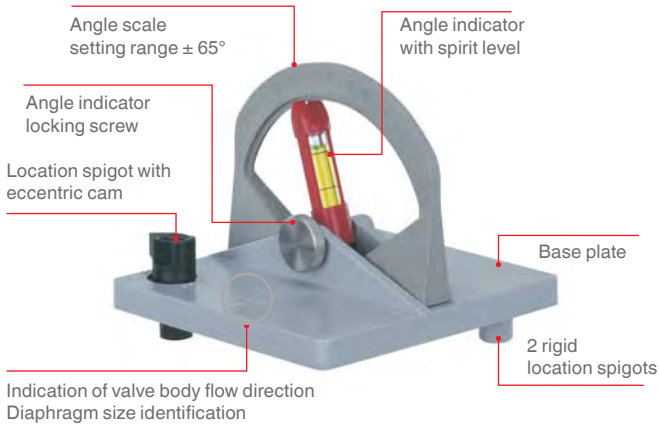

GEMÜ has developed a patented angle gauge to simplify mounting 2/2-way stainless steel diaphragm valve bodies. The angle gauge enables quick and simple determination of the correct mounting position of a diaphragm valve body. The angle gauge is placed on the valve body so that its location spigots engage in the holes intended for actuator fixing. It is then locked by an eccentric cam at one of the location spigots. The flow direction is clearly identified to prevent incorrect positioning. The correct installation angle, dependent on the valve body type, is indicated in this brochure. The given angle is set on the angle gauge. The valve body is rotated until the spirit is level. Then the body can be installed in the piping. The angle gauge is available for diaphragm sizes MG 8 - 100.

Please use the article numbers listed below when ordering:

- Angle gauge for diaphragm size 8: 88278996
- Angle gauge for diaphragm size 10: 88277372
- Angle gauge for diaphragm size 25: 88277373
- Angle gauge for diaphragm size 40: 88277374
- Angle gauge for diaphragm size 50: 88277375
- Angle gauge for diaphragm size 80: 88277376
- Angle gauge for diaphragm size 100: 88379424



Distributed by:

**Tri-Canada**

7033 Telford Way #20, Mississauga, ON L5S 1V4  
Tel: **905.677.9000** • Toll Free: **1.800.486.7863**  
[www.tricanada.com](http://www.tricanada.com)



**GEMÜ Gebr. Müller Apparatebau GmbH & Co. KG**  
Fritz-Müller-Straße 6-8 · D-74653 Ingelfingen-Criesbach  
Phone +49 (0)7940 123-0 · [info@gemu.de](mailto:info@gemu.de)

[www.gemu-group.com](http://www.gemu-group.com)